

EarthCARE
Cloud Profiling Radar (CPR)

Level 1b Algorithm Theoretical Basis Document
(L1b ATBD)

概要 Overview

This document describes theoretical basis of Level 1b algorithm, except for the spacecraft data processing. In other words, this ATBD describes algorithm relating to the radar data processing.

キーワード Key words	L1 ATBD													
	Algorithm													
	Product													
情報の区分	<input checked="" type="checkbox"/> 一般	<input type="checkbox"/> B 情報	<input type="checkbox"/> B 情報 (関係者限定)	<input type="checkbox"/> A 情報	<input type="checkbox"/> AA 情報									
開示制限解除年月	年 月													
個人情報の種類 (該当する場合のみ)	<input type="checkbox"/> B 個人情報						<input type="checkbox"/> A 個人情報							
Distribution List 配付先														
配付種類														
部数														
関連	承認 Approved by 伊藤 英一 Eishi Termita 2017.2.17			点検 Checked by 会中 裕 Kai Nakayoshi 2017.2.17			作成 Prepared by 大野 昌山 Sho Ono 2017.2.13			技術資料番号 Document No. SEC-140039			改訂符号 Revision B	
EarthCARE/CPR Project Team														

改訂記録
 Change record

符号 Revision	承認年月 日 Date	承認 Approved by	点検 Checked by	作成 Prepared by	改訂箇所 Changed Section	改訂内容、理由等 Description of Change
NC	Jan. 2015	E. Tomita	H. Nakatsuka Y. Aida Y. Seki K. Okada K. Maruyama Y. Iide T. Nio	Y. Ohno G. Kadosaki	N/A	初版制定 First Issue
A	Mar. 2015	E. Tomita	Y. Seki Y. Iide K. Maruyama	G. Kadosaki	Table 6 navigationLandS eaFlg	“65535=no data” and “This flag is based on GLOBCOVER” were added. (MOS-CDR-ME- 04)

B	Feb. 2017	E. Tomita	H. Nakatsuka Y. Aida T. Nio	Y. Ohno N. Tomiyama	<p>General</p> <p>Section 1.1</p> <p>Section 2.2</p> <p>Section 3</p> <p>Section 4.1</p> <p>Section 4.2</p> <p>Section 4.3</p> <p>Section 4.4</p> <p>Section 4.5</p> <p>Section 4.6</p>	<p>Modify the name of parameters so that those can be consistent with the definition in the PDD with respect to MOS-CDR-DL-05.</p> <p>Add the explanation that off-line calibrations, which mean the external calibration and sea surface calibration, are out of scope with respect to MOS-CDR-DL-01.</p> <p>Add the reference document.</p> <p>Update the documents with respect to the RDs and Figure 3. Add Table 3.1 with respect to a part of MOS-CDR-RK-03. Specify the database of DEM and Land/water mask with respect to MOS-CDR-RK02.</p> <p>Update the documents with respect to the updated Figure 4.1.</p> <p>Update the description from -0.5km to -1.0km with respect to CPR-ATB-PK-02.</p> <p>Update the vertical sampling window to 16,18 or 20km.</p> <p>Update the documents generally.</p> <p>Update the documents with respect to CPR-ATB-PK-02 and use of Land/Water mask (based on GlobCover) to distinguish land and ocean.</p> <p>Update the documents with respect to CPR-ATB-HO-02/03/04, CPR-ATB-PK-03, CPR-ATB-ME-04.</p> <p>Add the numerical formula for measuring the radar beam direction and its explanation with respect to CPR-ATB-RK-01 (same with CPR4ALL-SY-4, MOS-CDR-ME-05).</p> <p>Update the documents and Add the equation with respect to the spectrum width (sw).</p> <p>Update the documents with respect to the updated Figure 4.6.</p>
---	-----------	--------------	--------------------------------------	---------------------------	---	--

					Section 5	Add the explanation with respect to CPR-ATB-ME-06.
					Figure 3	Update the Figure 3 which is the flowchart of L1 processing with respect to CPR-ATB-ME-01
					Figure 4.1	Update the figure with respect to CPR-ATB-HO-05.
					Figure 4.4	Update the figure with respect to CPR-ATB-HO-04.
					Figure 4.7	Update the figure with respect to CPR-ATB-PK-05.

Table of Contents

1. INTRODUCTION	1
1.1 Scope	1
2. DOCUMENTS	1
2.1 Applicable documents	1
2.2 Reference documents.....	1
3. PRODUCT DEFINITION FOR LEVEL 1B PRODUCT	1
4. THEORETICAL DESCRIPTION OF L1b RADAR PROCESSING ALGORITHM.....	2
4.1 Received echo power.....	2
4.2 Radar reflectivity factor.....	3
4.3 sigma zero (Normalized surface scattering cross section).....	4
4.4 Doppler velocity	4
4.5 Spectral width.....	5
4.6 Transmit power.....	5
4.7 Surface estimation	6
5 OBSERVATION TIME	7
6 GEO LOCATION INFORMATION.....	7

1. INTRODUCTION

1.1 Scope

This document describes theoretical basis of Level 1b algorithm, except for the spacecraft data processing. In other words, this ATBD describes algorithm relating to calculation of physical radar data and radar calibration of EarthCARE/CPR. Since results of sea surface calibration or external calibration are not online type calibration, they are out of scope of this document.

2. DOCUMENTS

2.1 Applicable documents

NONE

2.2 Reference documents

- 1) EarthCARE Mission Requirements Documents Issue 5 Revision 0-2, November 2006
- 2) EarthCARE Algorithm Description Document, ver.1.2 (4 Aug 2003)
- 3) Phase A study report on cloud profiling radar for EarthCARE (part2) issue 1, November 2005
- 4) EC.ICD.ASD.SY.00004 EarthCARE Product Definitions Volume 0 - Introduction
- 5) EC.ICD.ASD.SY.00005 EarthCARE Product Definitions Volume 1 - Common Products Definitions
- 6) MAS-110009A EarthCARE/CPR Level1 Product File Format Specification
- 7) MAS-140030NC EarthCARE Product Definitions –JAXA L2 product format-
- 8) EC-ICD-ESA-SYS-299 Land/water mask for EarthCARE data processors: Format description

3. PRODUCT DEFINITION FOR LEVEL 1B PRODUCT

In CPR level 1b products, received echo power, radar reflectivity factor, NRCS (normalized surface scattering cross section), Doppler velocity, spectrum width, and data flag are included (see Fig. 3). Gaseous attenuation corrected radar reflectivity factor, unfolded Doppler velocity and various cloud microphysical parameters are not included in level 1b and are processed in level 2a and 2b of JAXA processing (RD7).

Figure 3 shows the flow chart of L1 algorithm. Major L1b output is designated as colored boxes. Input data list to L1b processing are shown in Table 3.1. In the L1 Processor, the database of DEM is ACE2. And Land/Water mask is prepared by ESA (RD8).

In Level 1a processing, order and continuity of level 0 data are checked before level 1b processing. The list of level 1b products, data format of products, time and location information of products, detail explanation of level 1b flags, and etc. are shown in RD6.

Table 3.1 List of input data for CPR L1 processing

Input data	Contents
Configuration files	Setting parameters and option for L1 processing
Level 0 product (ISP)	Science packet of CPR (Log detector, Pulse-Pair covariance, Tx monitor, observation configuration and parameter, etc.)
Satellite ancillary data	Orbit information file (GPS, reconstruction, predicted) Attitude information file
Auxiliary data	Instrument calibration data, PRF table, DEM, Land/Water mask

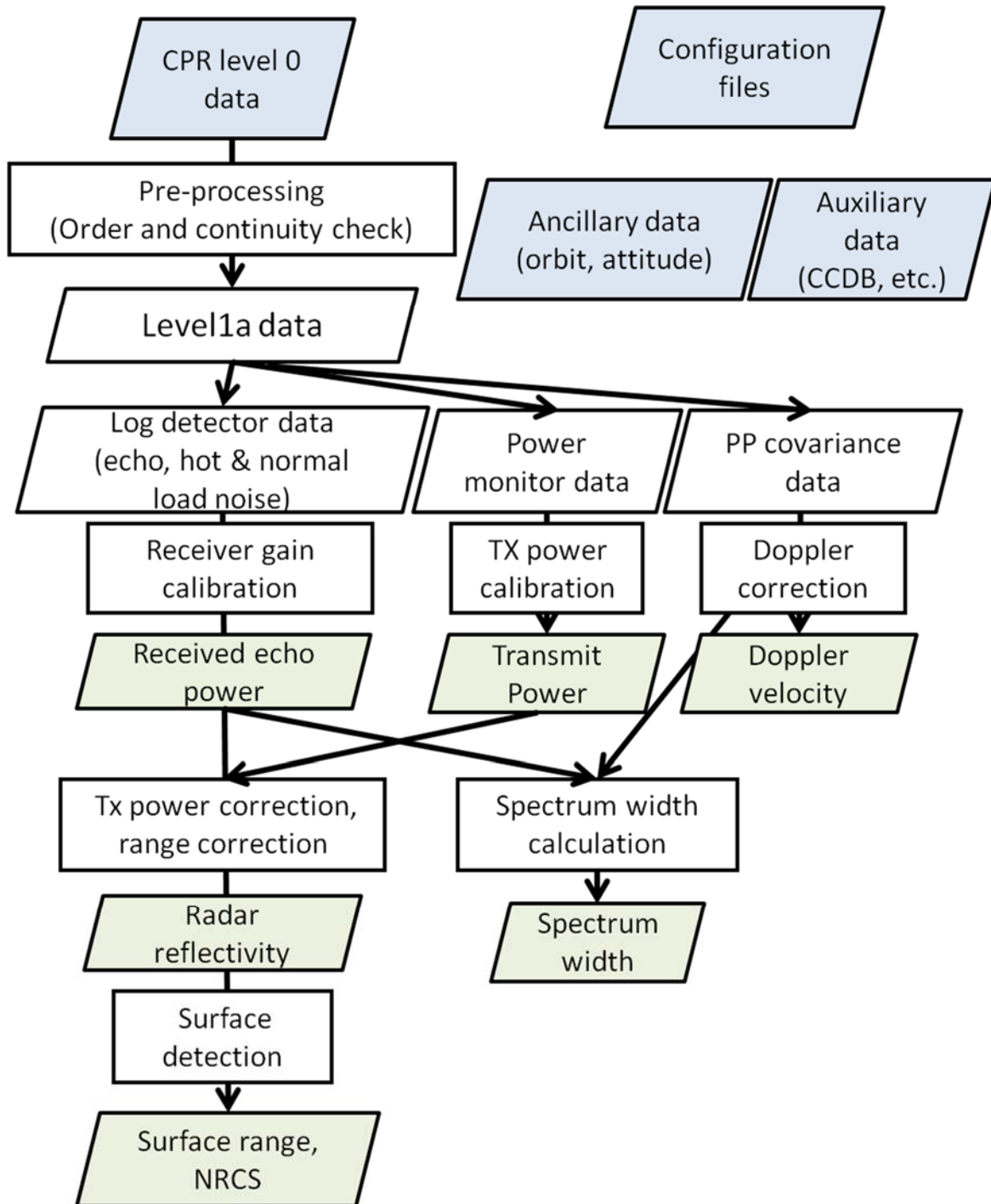

Figure 3 Flowchart for level 1 processing

4. THEORETICAL DESCRIPTION OF L1b RADAR PROCESSING ALGORITHM

4.1 Received echo power

Received echo power (P_r) is converted from the log detector output of CPR level 0 data. It is integrated with about 500m horizontal length on orbit. Mean P_r is calculated from division with integration number echo. Mean P_r is calibrated using receiver temperature, and calibration load data (hot & normal). Received echo power is distributed before noise power subtraction in consideration of horizontal integration in level 2 processing. Unit of received echo power is 'W'.

The vertical sampling window depends on the observation modes from -1.0 km below the ellipsoid model surface (WGS-84) to 16, 18 or 20 km above the ellipsoid surface for normal observation mode. Figure 4.1 shows the processing flow for received echo power and radar reflectivity factor.

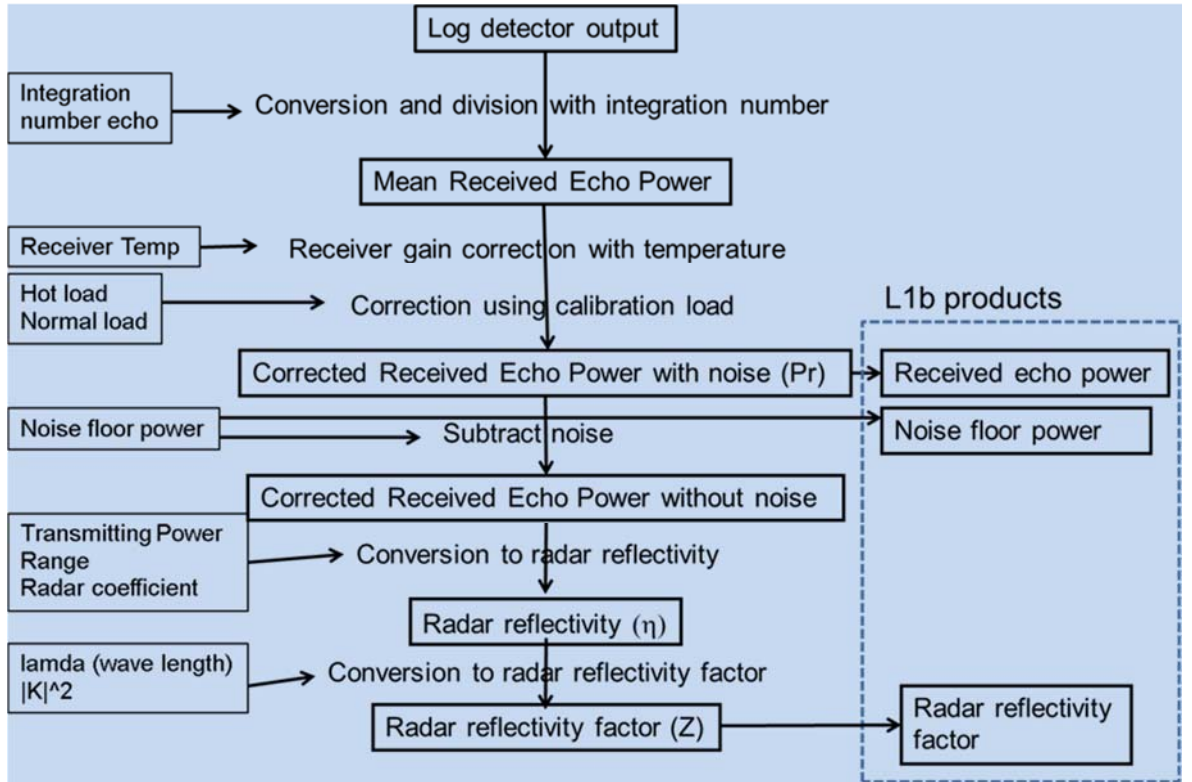

Figure 4.1 Processing for received echo power and radar reflectivity factor

4.2 Radar reflectivity factor

Radar reflectivity factor (Z) is converted from Received echo power (P_r) mentioned above. First, radar reflectivity (η) (volume scattering cross section) is calculated from the received echo powers (P_r), transmit power (P_t), and the radar calibration constant (C) as follows.

$$\eta = C \times \frac{P_r}{P_t} \times r^2$$

Where r is range to a target and P_t is calibrated with the transmit power monitor as written in sec 4.6. C is expressed as follows.

$$C = \frac{2^{10} (\ln 2) \pi^2 L}{G^2 \lambda^2 \theta^2 c \tau}$$

Where G is antenna gain at boresight, θ is half power beam width of antenna, λ is wave length of the radio wave, c is velocity of light, τ is pulse width, and L is loss factor. Then, the radar reflectivity factor Z is calculated as follows.

$$Z = \frac{\lambda^4}{\pi^5 |K|^2} \times \eta \times 10^{18}$$

Where $|K|^2$ is the normalizing dielectric factor. For EarthCARE/CPR, 0.75 is used for the normalizing dielectric factor $|K|^2$ corresponding to the liquid water value at 10 degree in 94GHz. Unit of radar reflectivity factor is 'mm⁶/m³'.

4.3 sigma zero (Normalized surface scattering cross section)

Sigma zero (σ^0) is the normalized radar reflectivity which corresponds to the land or ocean surface range. Sigma zero is a radar cross section divided by the real cross section. Using radar reflectivity at surface range ($\eta_{surface}$), sigma zero is calculated as follows.

$$\sigma^0 = \eta_{surface} \times \frac{c\tau}{2}$$

Unit of sigma zero is a ratio in 'dB'. Land and ocean surfaces range are inferred by surface estimation program written in section 4.7. In order to distinguish land or ocean, Land/Water mask prepared by ESA is used.

4.4 Doppler velocity

Doppler velocities represent vertical movement speeds of echoes if the beam direction of the EarthCARE/CPR is precisely nadir. Doppler velocity is derived from IQ detector output instead of log detector output of CPR level 0 data. Unit of Doppler velocity is 'm/s'. The echo phase angle (ϕ) (in radians) is converted from the ratio of the real and imaginary parts of pulse-pair covariance coefficients (PP). A phase change of transmit pulse (ϕ_0) measured from leak signal to CPR receiver during transmit is used for collection of echo phase angle (ϕ). Also, a phase correction (ϕ_{sat}) from satellite speed contamination to the radar beam direction (V_{sat}) is also calculated from ancillary data (satellite velocity, attitude, beam direction). Satellite speed contamination to the radar beam direction (V_{sat}) is calculated by dot product of the satellite velocity vector (\vec{v}_{sat}) and the unit vector of CPR beam direction (\vec{n}_{cpr}) as follows.

$$V_{sat} = \vec{v}_{sat} \cdot \vec{n}_{cpr}$$

$$\phi_{sat} = 4\pi \cdot V_{sat} / (\lambda \times PRF)$$

$$\phi = \arctan(\text{Im}PP / \text{Re}PP) - \phi_0 - \phi_{sat}$$

The Doppler velocity (V) is calculated as follows.

$$V = \frac{\phi \times \lambda \times PRF}{4\pi}$$

Where PRF is pulse repetition frequency. Since the maximum ambiguity Doppler velocity V_{max} is defined as follows, unfolding process should be introduced in level 2 processing.

$$V_{max} = \frac{\lambda \times PRF}{4}$$

Finally, vertical Doppler velocity from $-V_{max}$ to $+V_{max}$ is derived. Correction of non-uniform reflectivity effect is considered as Level 2 processing.

Figure 4.4 illustrates Doppler velocity processing in L1b.

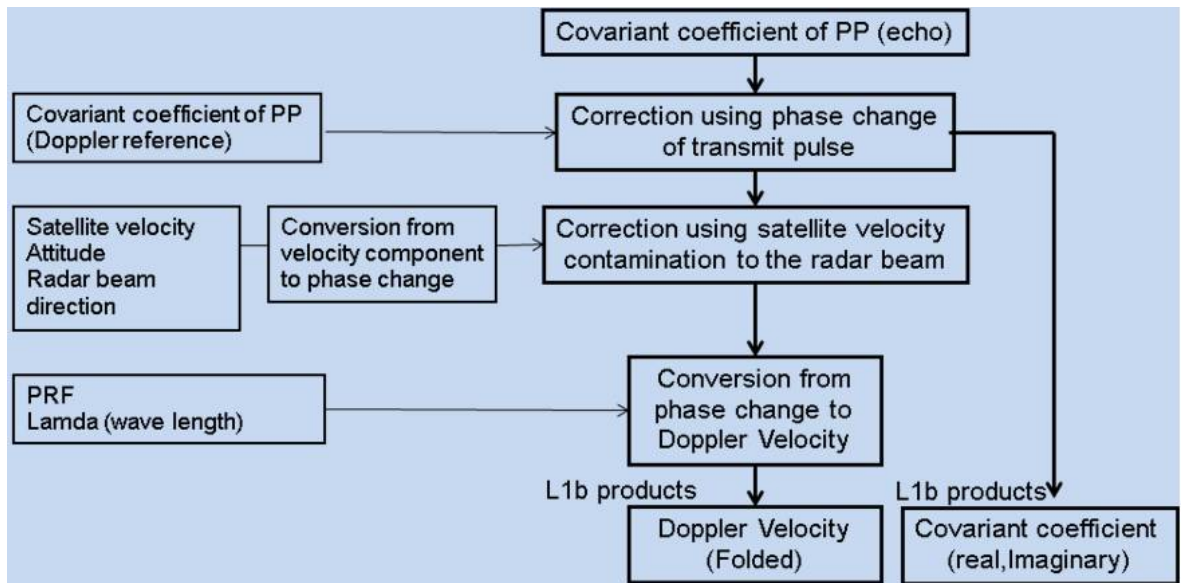

Figure 4.4 Doppler processing in L1b.

4.5 Spectral width

The spectrum width (sw) is the width of the Doppler velocity spectrum including spectrum spreading due to satellite velocity. Unit of spectral width is 'm/s'. In the pulse-pair method adopted in the EarthCARE/CPR, spectral width is calculated from the two covariance coefficients and radar reflectivity of the pulse-pair in level 0 data.

For this calculation, both the corrected covariance coefficient of pulse pair processing and received power are needed for the calculation.

$$sw = \frac{\lambda \times PRF}{2\sqrt{2}\pi} \sqrt{\ln\left(\frac{f(P_r - N)}{\sqrt{\text{Re}(PP)^2 + \text{Im}(PP)^2}}\right)}$$

4.6 Transmit power

Power detector diode is installed in the QOF and it can receive a part of RF transmit power. RF power is converted DC signal and transferred to the SPU. DC signal is converted to digital data and integrated pulse shape is recorded in level 0 data. Received leak pulse signal during transmit is additionally used for transmit power monitor. Figure 4.6 shows the processing flow of the transmit power. Firstly, pulse shape is checked, and if it has fine shape, pulse amplitude and pulse width is estimated. QOF and AD converter temperatures are used for calibration of DC signal. Transmit power is estimated from pulse amplitude with reference of the ground test data before launch.

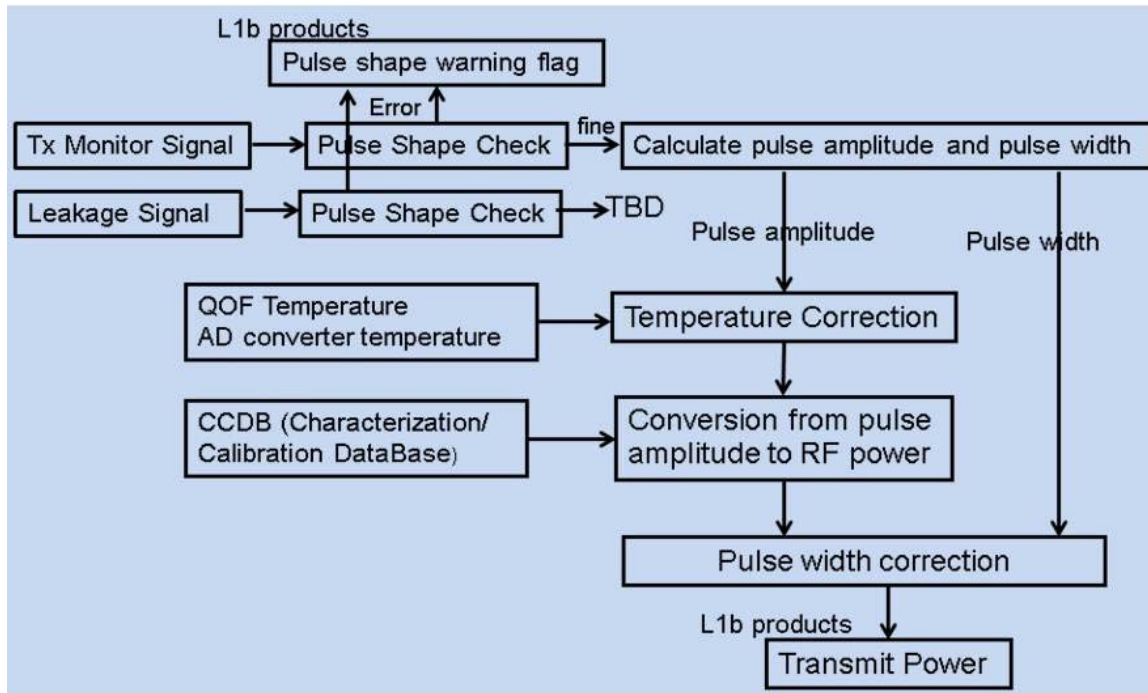

Figure 4.6 Transmit power calculation flow

4.7 Surface estimation

Surface echo range is important for the higher level CPR algorithm. In L1b, surface echo range bin is determined using received echo power profile with the help of DEM information. Also, the exact location of the surface within a pulse is calculated. In presence of drizzle and/or rainfall, CPR data suffer attenuation and the surface echo may disappear in heavy rainfall case. This processing produces both the range bin information of the surface and the quality flag of the surface estimation.

Figure 4.7 shows the processing flow for the surface echo detection.

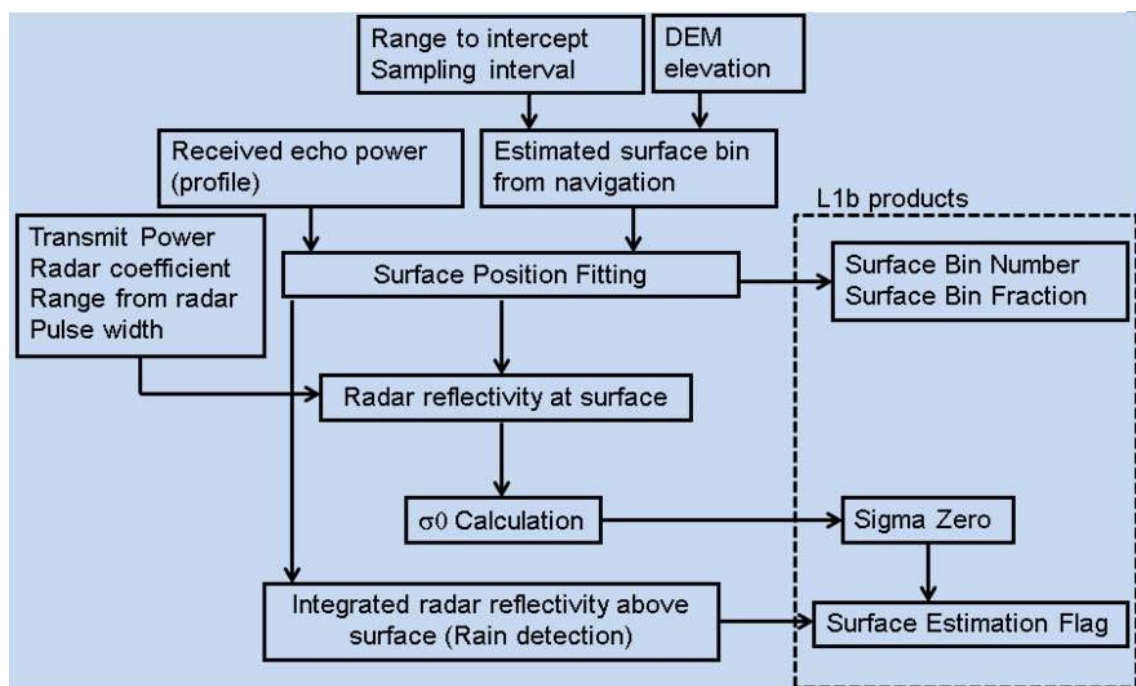

Figure 4.7 Processing flow for surface echo range

5 OBSERVATION TIME

CPR observation time (Profile time) of level 1b product is the time when CPR antenna beam footprint is located in the center of 500 m integration frame (shown in Figure 5 “B”).
The profile time is defined by the RF pulse transmitting time.

| B

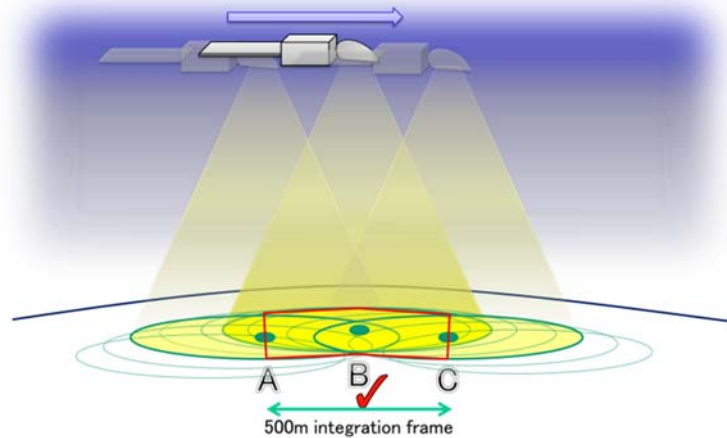

Figure 5 Definition of CPR observation time (Profile time)

6 GEO LOCATION INFORMATION

Geo location of CPR level 1b product shows the center of 500m integration frame on the ground as latitude and longitude (deg) with DEM elevation (m). Table 6 shows list of output contents of level 1b product relevant to geo location information.

Table 6. List of output contents of level 1b product relevant to geo location information

	name	explanation	unit	definition
1	latitude	latitude	deg	Geodetic latitude
2	longitude	longitude	deg	Geocentric Longitude
3	DEMElevation	DEM elevation	m	-
4	pitchAngle	pitch angle	deg	+ rotation means footprint offset to forward direction (local nadir = 0)
5	rollAngle	roll angle	deg	+ rotation means footprint offset to the left side (local nadir = 0)
6	yawAngle	yaw angle	deg	+ rotation means CW (clock wise) direction (flight direction = 0)
7	satelliteVelocityX	satellite velocity X	m/s	Flight direction
8	satelliteVelocityY	satellite velocity Y	m/s	Velocity orthogonal to the orbit plain
9	satelliteVelocityZ	satellite velocity Z	m/s	Nadir direction
10	xPosition	satellite position X	m	Earth fixed coordinate
11	yPosition	satellite position Y	m	Earth fixed coordinate
12	zPosition	satellite position Z	m	Earth fixed coordinate
13	navigationLandSeaFlg	navigation land sea flag	-	<u>This flag is based on Land/Water mask (RD8)</u>
14	rayHeaderSpatAvg	ray header spatial average	m	500 m integrated distance*

A
B

*depends on PRF setting