



METRIA



Image2006

*GMES Fast Track Land Service 2006-2008
Orthorectification of SPOT and IRS-P6 products*

Doc. No.: *Image2006*

Issue: *1.0*

Date: *12th May 2009*

Page: *1*



IMAGE2006

European Coverage

Methodology and Results

Prepared by

DLR

Rupert Müller, Thomas Krauß, Manfred Lehner, Peter Reinartz

METRIA

Jörgen Forsgren, Göte Rönnbäck, Åke Karlsson



METRIA



INGÅR I LANTMÄTERIET

Image2006

GMES Fast Track Land Service 2006-2008
Orthorectification of SPOT and IRS-P6 products

Doc. No.: *Image2006*

Issue: *1.0*

Date: *12th May 2009*

Page: *2*

– blank page –



Image2006

GMES Fast Track Land Service 2006-2008
Orthorectification of SPOT and IRS-P6 products

Doc. No.: *Image2006*
Issue: *1.0*
Date: *12th May 2009*
Page: *3*

CONTENTS

1. SUMMARY	6
1.1 Background.....	6
1.2 Methods.....	6
1.3 Results.....	6
2. References	8
2.1 Informative References.....	8
2.2 External References.....	8
2.3 Copyrights.....	11
3. Terms, Definitions and Abbreviated Terms	12
3.1 Terms and Definitions.....	12
3.2 Abbreviated Terms.....	12
4. Introduction	15
4.1 Background.....	15
4.2 Overview.....	15
5. Satellite Images	17
6. Methodology	19
6.1 Methodology of DLR.....	19
6.1.1 Orthorectification by Direct Georeferencing.....	19
6.1.2 Orthorectification by Rational Polynomial Functions.....	24
6.1.3 Automatic Processing Chain.....	25
6.1.4 Processing Infrastructure.....	29
6.1.5 Digital Elevation Model (DLR).....	31
6.1.6 Reference Data Sets.....	32
6.1.7 Limitations and Experiences of Data Processing.....	33
6.1.8 GCP Chip Selection Process.....	35
6.2 Methodology of METRIA.....	36
6.2.1 Line-of-sight model.....	37
6.2.2 Ortho-rectification.....	39
6.2.3 Model parameter adjustment.....	39
6.2.4 Geometric accuracy performance.....	40
6.2.5 Digital Elevation Model (METRIA).....	40
7. Statistics and Results	41
7.1 Orthorectification Product.....	41
7.2 GCP Chip Database Product.....	48
8. Appendix 1: Country Reference Systems CRS	50
9. Appendix 2: Comments on Accuracy Assessment	51
10. Appendix 3: Country Codes	52
11. Appendix 4: Quality Record - Description	53

LIST OF FIGURES

Figure 6-1	Levels of Orthorectification	20
Figure 6-2	Concept of Direct Georeferencing (Line-of-Sight Model)	21
Figure 6-3	Operational automatic processing chain for orthoimage production and manual QC	28
Figure 6-4	System Hardware for IMAGE2006.....	30
Figure 6-5	Monitoring concept of H/W and S/W for Image2006.....	30
Figure 6-6	WEB based interface for image administration and processing (intermediate state)	31
Figure 6-7	Digital Elevation Model DEM used at DLR for orthorectification	32
Figure 6-8	Deviations in pixel – factor 55 enlarged – of automatically determined ICPs from the reference image versus image coordinates of the orthorectified scene (SPOT 4) after correction with GCPs (RMSE _x =12.4m, RMSE _y =8.0m)	34
Figure 6-9	Deviations in pixel – factor 54 enlarged – of automatically determined ICPs from the reference image versus image coordinates of the orthorectified scene (SPOT 4) after correction with GCPs (RMSE _x =12.6m, RMSE _y =12.3m)	34
Figure 6-10	GCP Chip Image	35
Figure 6-11	Examples of GCP chip images	36
Figure 6-12	The generic observation model used in SIP/Ortho	38
Figure 9-1	Different Accuracy Specifications	51



METRIA



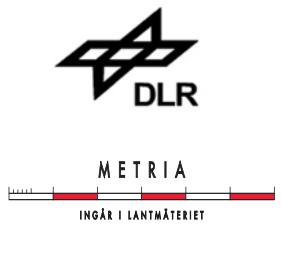

Image2006

GMES Fast Track Land Service 2006-2008
Orthorectification of SPOT and IRS-P6 products

Doc. No.: *Image2006*
Issue: *1.0*
Date: *12th May 2009*
Page: *5*

LIST OF TABLES

Table 5-1	Sensor systems	17
Table 6-1	Throughput values in hours for one workstation	29
Table 6-2	Absolute geolocation accuracy of reference images derived from 12 GCPs of superior quality in southern Bavaria.....	33
Table 7-1	Documents containing detailed information for each country and each processed scene	41
Table 7-2	Geometric accuracy (w.r.t. reference images) of orthorectified country datasets	47
Table 7-3	GCP image chip database on a country basis	49
Table 10-1	Official Country Codes of EU38	52
Table 11-1	Quality Control – Meanings of parameters	53

		<p style="text-align: center;"><i>GMES Fast Track Land Service 2006-2008 Orthorectification of SPOT and IRS-P6 products</i></p> <p>Doc. No.: <i>Image2006</i></p> <p>Issue: <i>1.0</i></p> <p>Date: <i>12th May 2009</i></p> <p>Page: <i>6</i></p>
---	---	---

1. SUMMARY

1.1 Background

Within the GMES Fast Track Land Service 2006-2008 a new dataset of orthorectified satellite images has been produced by DLR under ESA contract covering the participating EU27 and neighboring countries (total 38 countries). About 3800 satellite images (two multi-temporal European coverages at different satellite image acquisition windows for improved discrimination of the vegetation classes) have been processed within a time frame of less than one year including quality control and creation of a European wide consistent GCP database. For countries above 60° Latitude – namely Sweden, Finland, Norway and Iceland – the orthorectification of the image scenes are subcontracted by DLR to the Swedish company METRIA. The orthorectified products are derived from a mixture of high resolution satellite images from SPOT 4 HRVIR with 20m GSD, SPOT 5 HRG with 10m GSD and IRS-P6 LISS III with 23m GSD, each with four spectral bands, and geometrically corrected towards European Map Projection with 25m resolution and National Map Projection for each country with 20m resolution. For the final resampling cubic convolution interpolation is applied. The overall geometric accuracy requirement is stated to be better than 20m RMSE in each direction with respect to the European Land Cover dataset Image2000 (EU25) and USGS ETM+ Land Cover dataset (neighboring countries).

1.2 Methods

For SPOT4/5 the Line-of-Sight vector is derived from continuous measurements of the state vectors and attitude parameters as well as the calibrated camera model provided by SpotImage in DIMAP format. For IRS-P6 LISS III the RPCs (Rational Polynomial Coefficients) serve as orientation input, which are provided by Euromap as a Universal Sensor Model in the OrthoKit format. Further input for the ortho-rectification is – in case of DLR – the European wide digital elevation model (DEM) from SRTM-C band Version 2 of NASA, improved by using inputs from MONAPRO, SRTM-X band DEM and GLOBE within a fusion process using accuracy layers for the different DEM databases and – in case of METRIA – other special DEM databases described in the report. In order to achieve the required geometric accuracy of 20m RMSE, ground control points (GCPs) are used to improve the parameters of the (physical) models. In case of DLR are these GCPs are automatically (via image matching between the Image2000 / USGS Land Cover dataset and the new satellite scenes) and/or manually determined. From these derived GCPs, corrections of the orientation for SPOT4/5 and affine transformation parameters of the RPC for IRS-P6 LISS III are derived. Quality assessment is based on ICPs (Independent Control Points), from which mean RMSE values for each scene and whole countries are derived or from which residual plots are produced.

1.3 Results

A relative geometric accuracy of the about 3800 orthorectified scenes is reached better than 10 m RMSE in each direction with respect to the IMAGE2000 and USGS Land Cover reference datasets, which corresponds to half a pixel size. The accuracy assessment is based on ~450 automatically extracted ICPs per 1000 km². The absolute geometric accuracy assessment is still in progress with first results of about 6 m RMSE in each direction. A European wide consistent GCP image chip database has been established with about 5 GCPs per 1000 km² (in totally about 60.000 GCP image chips). Less than 5 % of the images

have to be processed manually (additional GCP measurements) in cases the product does not pass the internal quality control.

Figure 1.1 shows the results broken down into the processed countries and the two coverages. The first two columns of each country show the RMS errors in x (east) and y (north) direction for the first coverage. The last two columns are valid for the second coverage. For SPOT4/5 and IRS-P6 orthorectified scenes an overall geometric accuracy with respect to the reference images (relative error) of about 10 m RMSE in each direction is reached (for Spot4/5: $RMSE_x=10.4$ m , $RMSE_y=8.6$ m and for IRSP6: $RMSE_x=9.7$ m , $RMSE_y=8.0$ m)

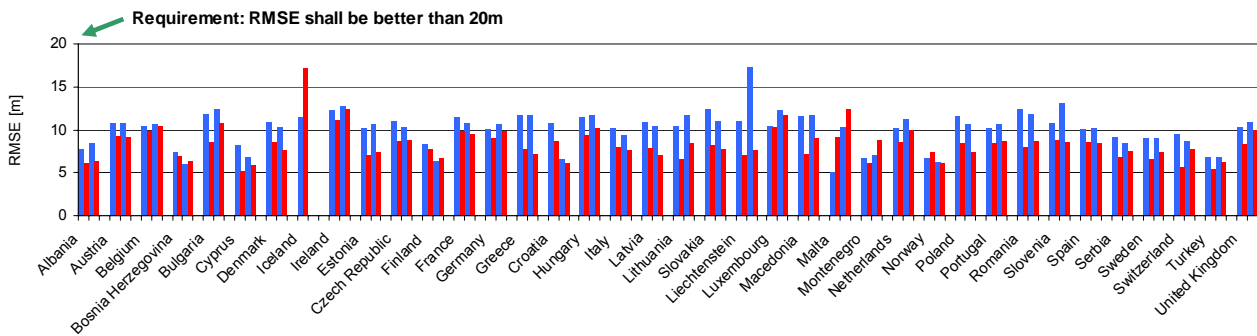
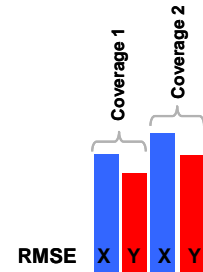

Figure 1.1 Geometric accuracy (RMSE) of Image2006 products w.r.t. reference images (relative accuracy). $RMSE_x$ (blue) and $RMSE_y$ (red) for European coverage 1 (first two columns of country) and European coverage 2 (last two columns of country)

 		<p style="text-align: center;"><i>GMES Fast Track Land Service 2006-2008 Orthorectification of SPOT and IRS-P6 products</i></p> <p>Doc. No.: <i>Image2006</i></p> <p>Issue: <i>1.0</i></p> <p>Date: <i>12th May 2009</i></p> <p>Page: <i>8</i></p>
--	---	---

2. References

2.1 Informative References

The following documents, though not a formally part of this document, amplify or classify its contents.



Ref	Title of Document / Issue / Date
ID-01	CORINE Land Cover updating for the year 2000 – IMAGE2000 and CLC2000 – Products and Methods. EUR21757 EN, ISBN 92-894-9862-5
ID-02	GMES Fast Track Land Service 2006-2008, Data provision from SPOT and IRS-P6 satellite Interface Control Document from Spot Image in response to ESA RFQ/3-11830/06/I-LG
ID-03	“Guidelines for Best Practice and Quality Checking of Ortho Imagery”, Issue 2.5; 2003; EUROPEAN COMMISSION DIRECTORATE GENERAL, JRC JOINT RESEARCH CENTRE – ISPRA Institute for the Protection and Security of the Citizen, Monitoring Agriculture with Remote Sensing Unit;
ID-04	“Map Projections for Europe”: Edited by A. Annoni, C. Luzet, E. Gubler, J. Ihde; 2003; Institute for Environment and Sustainability;
ID-05	SPOT IMAGE, 2002: “SPOT Satellite Geometry Handbook” S-NT-73-12-SI, Edition 1, Rev. 0, Toulouse, France. http://www.spotimage.fr/dimap/spec/dimap.htm
ID-06	“IRS-P6 LGSOWG (Super Structure)” DIGITAL DATA PRODUCTS FORMAT DPSD/SIPG/SIIPA Space Applications Centre, ISRO, Ahmedabad, INDIA; May 2003 http://www.Euromap.de/download/p6super_20050222.pdf
ID-07	Final Report for the Project IMAGE2000, Agreement 12440-96-12 F3AD ISP S , Reference 99/00/57/003, Document ID:M030601, Jörgen Forsgren
ID-08	GMES Fast Track Service on Land Monitoring , EEA Project Implementation Plan GMES Land FTS 2006-2008, AMP 2006 – 1.2.4 CST / AMP 2007 – 1.2.6 ASO, Issue: draft, Revision: 5, Date of issue: 09.10.06
ID-09	Soukop, T. ; I&CLC2000 CRS Database , Technical Documentation ; GISAT ; 13.10.2006
ID-10	GMES Fast Track Service on Land Monitoring, EEA Project Implementation Plan GMES Land FTS 2006-2008, AMP 2006 – 1.2.4 CST / AMP 2007 – 1.2.6 ASO, 2006
ID-11	PPT Final Presentation image2006

Table 2-1 Informative References



2.2 External References

The following documents are technical and scientific references

Ref	Title of Reference
RD-1	Toutin, T. (2004). Review Paper: Geometric Processing of Remote Sensing Images:Models, Algorithms and Methods. International Journal of Remote Sensing, vol. 25, no. 10, pp. 1893-1924(32).
RD-2	Spot Image (2005). Preprocessing Levels and Location Accuracy. Technical Information Brochure.
RD-3	Bouillon, A., and Gigord, P. (2004). SPOT 5 HRS Location Performance Tuning and Monitoring Principles. Proceedings ISPRS Congress in Istanbul, July 2004.
RD-4	Müller, Rupert; Lehner, Manfred; Reinartz, Peter; Schroeder, Manfred (2005): EVALUATION OF SPACEBORNE AND AIRBORNE LINE SCANNER IMAGES USING A GENERIC ORTHO IMAGE PROCESSOR. In: Heipke, C.; Jacobsen, K.; Gerke, M. [Hrsg.]: High Resolution Earth Imaging for Geospatial Information, IAPRS, Vol. XXXVI, High Resolution Earth Imaging for Geospatial Information, Hannover, 17.-20. Mai 2005, ISBN ISSN No. 1682-1777.



 		<p style="text-align: center;"><i>GMES Fast Track Land Service 2006-2008 Orthorectification of SPOT and IRS-P6 products</i></p> <p>Doc. No.: <i>Image2006</i></p> <p>Issue: <i>1.0</i></p> <p>Date: <i>12th May 2009</i></p> <p>Page: <i>9</i></p>
--	---	---

Ref	Title of Reference
RD-5	Daniela Poli (2005): Modelling of Spaceborne Linear Array Sensors; Diss. ETH NO. 15894; Institut für Geodäsie und Photogrammetrie; ETH Zürich; ISBN 3-906467-50-3.
RD-6	Reinartz, Peter; Lehner, Manfred; Müller, Rupert; Schroeder, Manfred (2004): Accuracy for DEM and Orthoimages derived from SPOT HRS Stereo Data without using GCP. In: Altan, M. Orhan [Hrsg.]: ISPRS Congress Proceedings 2004, International Archives of the Photogrammetry, Remote Sensing and Spatial Information Science, 35, Part B1, S. 433 – 438, ISPRS Congress, Istanbul, July 2004, ISBN 1682-1750.
RD-7	Lehner, M. (1986): Triple stereoscopic imagery simulation and digital image correlation for MEOSS project, Proceedings of ISPRS Commission I Symposium, pp. 477-484, Stuttgart, Germany
RD-8	Lehner M. and Gill R.S. (1992): Semi-automatic derivation of digital elevation models from stereoscopic 3-line scanner data, IAPRS, Vol. 29, Part B4, Washington, USA, pp. 68-75.
RD-9	Kornus W., Lehner M., Ebner H., Fröba H., Ohlhof T. (1999): Photogrammetric point determination and DEM generation using MOMS-2P/PRIRODA three-line imagery <i>Geo-Information-Systeme (GIS)</i> Vol. 12, December 1999, pp.28-36, Wichmann Verlag
RD-10	Kornus, W., Lehner, M., Schroeder, M. (2000): Geometric in-flight calibration of the stereoscopic line-CCD scanner MOMS-2P; ISPRS Journal of Photogrammetry & Remote Sensing, Vol. 55, pp. 59-71
RD-11	Baltasvias, E., Li, Z., Eisenbeiss, H. (2006): DSM Generation and Interior Orientation Determination of IKONOS Images Using a Testfield in Switzerland, DGPF, Photogrammetrie-Fernerkundung-Geoinformation, Issue 1, 2006
RD-12	SPOT IMAGE, "SPOT Satellite Geometry Handbook", S-NT-73-12-SI, Edition 1, Rev. 0, Toulouse, France 2002
RD-13	Reinartz, P., Müller, R., Lehner, M., Schroeder, M.: Accuracy Analysis for DSM and orthoimages derived from SPOT HRS Stereo Data using Direct Georeferencing, ISPRS Journal of Photogrammetry and Remote Sensing, Vol. 60/3, (2006), pp. 160-169
RD-14	CORINE Land Cover updating for the year 2000 – IMAGE2000 and CLC2000 – Products and methods. EUR21757 EN, ISBN 92-894-9862-5 [RD01 in SoW]
RD-15	Map Projections of Europe; European Commission, JRC; 2003
RD-16	Lehner, Manfred; Müller, Rupert; Reinartz, Peter (2005): DSM and Orthoimages from QuickBird and Ikonos Data using Rational Polynomial Functions . In: Heipke, C.; Jacobsen, K.; Gerke, M. [Hrsg.]: High Resolution Earth Imaging for Geospatial Information, IAPRS, Vol. XXXVI, S. CD-ROM -, High Resolution Earth Imaging for Geospatial Information, Hannover, 17.-20. Mai 2005, ISBN ISSN No. 1682-1777
RD-17	Lehner, M., Müller, Rupert, Reinartz, P., 2006: Stereo Evaluation of CARTOSAT-1 Data on Test Site 5 – First DLR Results, Proceedings of ISPRS-TC IV Symposium, Sept. 27-30, Goa, India
RD-18	Westin, T.: Precision rectification of SPOT imagery. Photogrammetric Engineering & Remote Sensing, Vol. 56, No. 2, February 1990, pp. 247-253.
RD-19	Westin, T.: Pass processing and extrapolation of SPOT image geometry. Photogrammetric Record, 13(78), 1991, pp. 919-925.
RD-20	Westin, T.: Empirical models for attitude variability of the SPOT 1 satellite, Photogrammetric Record, 13(78), 1991, pp. 913-918.
RD-21	Westin, T.: Empirical models for attitude variability of the SPOT 1 satellite, Photogrammetric Record, 13(78), 1991, pp. 913-918.
RD-22	Westin, T., Inflight calibration of SPOT CCD detector geometry. Photogrammetric Engineering & Remote Sensing, Vol. 58, No. 9, September 1992, pp. 1313-1319.
RD-23	Westin, T., Photogrammetric Potential of JERS-1 OPS. International Archives of Photogrammetry and Remote Sensing. Vol. XXXI, Part B4, Vienna 1996, pp. 937-942.
RD-24	Westin, T., 1994: Geometric rectification of JERS-1 OPS VNIR scenes. Proceedings of the "Results Reporting Meeting of JERS-1 System Verification Program", Tokyo, Nov.29 – Dec.1, 1994.

 <p>METRIA INGÅR I LANTMÄTERIET</p>		<p style="text-align: center;"><i>GMES Fast Track Land Service 2006-2008 Orthorectification of SPOT and IRS-P6 products</i></p> <p>Doc. No.: <i>Image2006</i> Issue: <i>1.0</i> Date: <i>12th May 2009</i> Page: <i>10</i></p>
--	---	---

Ref	Title of Reference
RD-25	Westin, T.: Geometric Rectification of European Historical Archives of Landsat 1-3 MSS Imagery. Proceedings of the ISPRS workshop "Sensors and Mapping From Space 1999", Hannover, Germany, September 27-30, 1999.
RD-26	Westin, T., Geometric Rectification of European Historical Archives of Landsat 1-3 MSS Imagery. Proceedings of the ISPRS workshop "Sensors and Mapping From Space 1999", Hannover, Germany, September 27-30, 1999.
RD-27	Westin, T.: Geometric Modelling of Imagery from the MSU-SK Conical Scanner. Bulletin SFPT, no 159, pp. 55-58, 2000.
RD-28	Westin, T., and Forsgren, J., 2001: Orthorectification of EROS A1 images. IEEE/ISPRS Joint Workshop on "Remote Sensing and Data Fusion Over Urban Areas", Rome, Nov. 8-9, 2001
RD-29	Müller, R.; Krauß, T.; Lehner, M.; Reinartz, P. (2007): Automatic Production of European Orthoimage Coverage within the GMES Land Fast Track Service using SPOT 4/5 and IRS-P6 LISS III Data; In: Heipke, C.; Jacobsen, K.; Gerke, M. [Hrsg.]: ISPRS Hannover Workshop 2007, High Resolution Earth Imaging for Geospatial Information, Hannover, 2007-05-29 – 2007-06-01, ISSN 1682-1777
RD-30	Bouillon, A., Breton, E., De Lussy, F., Gachet, R., 2003. SPOT5 Geometric Image Quality, Proc. IGARSS 2003, Toulouse, July 21-25 July 8p. (on CD-ROM).
RD-31	Roth, A.; Knöpfle, W.; Strunz, G.; Lehner, M.; Reinartz, P.; 2002: "Towards a Global Elevation Product: Combination of Multi-Source Digital Elevation Models", Symposium on Geospatial Theory, Processing and Applications, Ottawa, 2002
RD-32	Grodecki, J., Dial, G., Lutes, J., 2004. Mathematical Model for 3D feature extraction from multiple satellite images described by RPCs. ASPRS Annual Conference Proceedings, Denver, Colorado
RD-33	Müller, Rupert und Krauß, Thomas und Lehner, Manfred und Reinartz, Peter und Schroeder, Manfred und Hörsch, Bianca (2008) GMES Fast Track Land Service 2006-2008 - Orthorectification of SPOT 4/5 and IRS-P6 LISS III Data . In: ISPRS Congress Beijing 2008, 2008, Beijing

Table 2-2 External References

		<p style="text-align: center;"><i>GMES Fast Track Land Service 2006-2008 Orthorectification of SPOT and IRS-P6 products</i></p> <p>Doc. No.: <i>Image2006</i> Issue: <i>1.0</i> Date: <i>12th May 2009</i> Page: <i>11</i></p>
---	---	--

2.3 Copyrights

The following copyrights are valid for the document in hands.

For SpotImage (Spot 4/5)

© CNES 2007 Distribution Spot Image S.A., France, all rights reserved; produced by DLR/Metria – data provided under an ESA contract for FTS LM IMAGE2006



For Euromap (IRS-P6 LISS III)

© ANTRIX Corporation Limited 2007, Distribution by Euromap GmbH, Germany, all rights reserved; produced by DLR/Metria – data provided under an ESA contract for FTS LM IMAGE2006

For Image2000 and CLC2000

© European Communities, Source: Joint Research Centre IMAGE2000, based on Landsat 7 ETM+ © ESA, distributed by Eurimage; ortho-correction EU15 © Metria, ortho-correction other countries GISAT; mosaic production GISAT



		<p style="text-align: center;"><i>GMES Fast Track Land Service 2006-2008 Orthorectification of SPOT and IRS-P6 products</i></p> <p>Doc. No.: <i>Image2006</i> Issue: <i>1.0</i> Date: <i>12th May 2009</i> Page: <i>12</i></p>
---	---	--

3. Terms, Definitions and Abbreviated Terms

3.1 Terms and Definitions

Term	Definition
Validation	Confirmation, through the provision of objective evidence, that the requirements for a specific intended use or application have been fulfilled (ISO 9000:200) Note: The validation process (for software) is the process to confirm that the requirements baseline functions and performances are correctly and completely implemented in the final product (ECSS-E-40 Part 1B)
Verification	Confirmation, through the provision of objective evidence, that specified requirements have been fulfilled (ISO 9000:200) Note: The verification process (for software) is the process to confirm that adequate specifications and inputs exist for any activity, and that the outputs of the activities are correct and consistent with the specifications and input (ECSS-E-40 Part 1B)
GeoTIFF	www.geotiff.org
DIMAP	http://www.spotimage.fr/dimap/spec/dimap.htm
XDibias	Image Processing System (DLR in-house development) www.dlr.de

3.2 Abbreviated Terms

Term	Meaning
AD	Applicable Document
BSQ	Band Sequential
BIL	Band Interleaved by Line
CCD	Charged Coupled Device
CLC	CORINE Land Cover
COTS	Commercial of the Shell Software
CRS	Country Reference System
CSE	Circular Standard Error
DLR	Deutsches Zentrum für Luft- und Raumfahrt www.dlr.de
DVD	Digital Versatile Disc
ESA	European Space Agency
GCP	Ground Control Point
GMES	Global Monitoring for Environment and Security
GPS	Global Positioning System
GSD	Ground Sampling Distance
DEM	Digital Elevation Model



METRIA



Image2006

GMES Fast Track Land Service 2006-2008
Orthorectification of SPOT and IRS-P6 products

Doc. No.: Image2006

Issue: 1.0

Date: 12th May 2009

Page: 13

Term	Meaning
DG	Direct Georeferencing
DLR	Deutsches Zentrum für Luft- und Raumfahrt (German Aerospace Centre)
DORIS	Doppler Orbitography and Radiopositioning Integrated by Satellite
DSM	Digital Surface Model
DTM	Digital Terrain Model
ECEF	Earth Centred Earth Fixed
ECI	Earth Centred Inertial
ECR	Earth Centred Rotated
EEA	European Environment Agency
EGM96	Earth Gravity Model 1996
EPSG	European Petroleum Survey Group
ESA	European Space Agency
ETM+	Enhanced Thematic Mapper
ETRF89	European Terrestrial Reference Frame 1989
EU	European Union
FTLS	Fast Track Land Service
HOM	Hotine Oblique Mercator
ICP	Independent Control Point
HRG	Haute Résolution Géométrique (High Geometric Resolution)
HRVIR	High Resolution Visible and Infrared
ICD	Interface Control Document
IP	Image Point
IRS	Indian Remote Sensing
ID	Informative Document
IMU	Inertial Measurement System
IRS	Indian Remote Sensing
ITRF89	International Terrestrial Reference System 1989
JRC	Joint Research Centre
LAEA	Lambert Azimuthal Equal Area
LCC	Lambert Conformal Conic
LFTS	Land Fast Track Service
LoS	Line of Sight
METRIA	Swedish Company http://www.spacemetric.com
MSPE	Mean Square Positional Error
NIR	Near Infrared
OAR	Quality Assurance Record
QA	Quality Assurance
QC	Quality Control
QR	Quality Record
RD	Reference Document
RMSE	Root Mean Square Error
RPC	Rational Polynomial Coefficients
RPF	Rational Polynomial Function
RSM	Replacement Sensor Model (see also RPC, RPF)
SAR	Synthetic Aperture Radar
SoW	Statement of Work
SMS	Short Message Service



METRIA



Image2006

GMES Fast Track Land Service 2006-2008
Orthorectification of SPOT and IRS-P6 products



Doc. No.: *Image2006*

Issue: *1.0*

Date: *12th May 2009*

Page: *14*

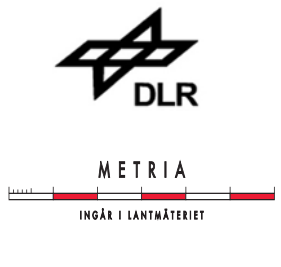
Term	Meaning
SPOT	Satellite Pour l'Observation de la Terre
SQL	Structured Query Language
SRTM	Shuttle Radar Topography Mission
STS	Star Tracker System
SWIR	Short Wave Infrared
TM	Transverse Mercator (Map Projection)
TM	Thematic Mapper (Sensor System)
TP	Tie Point
USB	Universal Serial Bus
USGS	United States Geological Survey
USM	Universal Sensor Model
UTC	Universal Time Coordinated
UTM	Universal Transverse Mercator
WBS	Work Breakdown Structure
WGS84	World Geodetic System 1984
XML	Extended Markup Language
2D	Two dimensional
3D	Three dimensional

		<p style="text-align: center;"><i>GMES Fast Track Land Service 2006-2008 Orthorectification of SPOT and IRS-P6 products</i></p> <p>Doc. No.: <i>Image2006</i></p> <p>Issue: <i>1.0</i></p> <p>Date: <i>12th May 2009</i></p> <p>Page: <i>15</i></p>
---	---	--

4. Introduction



4.1 Background

The GMES (Global Monitoring for Environment and Security) Fast Track Land monitoring Service (FTLS) is a service to provide on a regular basis land cover and land use change datasets, which can be used by a wide range of downstream services at European, National, regional and local scale. Since the mid 1980's a European Land Cover dataset has been regularly produced with now an increased frequency update to every five years from every ten years, taking 2006 as the current update year. The major products of the GMES land monitoring core service are European wide, high quality orthorectified satellite images for the reference year 2006 (+/- 1 year) (referred to as **IMAGE2006**) and based on the orthorectified images a European mosaic (referred to as **MOSAIC2006**), Corine land cover changes 2000-2006 (referred to as **CLC2006**), Corine land cover map 2006, high resolution core land cover data for built-up areas, including degree of soil sealing and high resolution core land cover data for forest areas, including leaf type [see also ID-10].





4.2 Overview

Within the GMES Fast Track Land Service 2006-2008 a new dataset of orthorectified satellite images has been produced by DLR (four countries are subcontracted by DLR to METRIA) under ESA contract covering the participating EU27 and neighboring countries (total 38 countries). In order to process about 3800 satellite images (two multi-temporal European coverages at different satellite image acquisition windows for improved discrimination of the vegetation classes) DLR established an automatic and operational processing chain for the orthorectification within a time frame of less than one year including quality control and creation of a European wide consistent GCP database. For countries above 60° Latitude – namely Sweden, Finland, Norway and Iceland – the orthorectification of the image scenes are subcontracted by DLR to the Swedish company METRIA.

The orthorectified products are derived from a mixture of high resolution satellite images from SPOT 4 HRVIR with 20m GSD, SPOT 5 HRG with 10m GSD and IRS-P6 LISS III with 23m GSD, each with four spectral bands, and geometrically corrected towards European Map Projection with 25m resolution and National Map Projection for each country with 20m resolution. For the final resampling cubic convolution interpolation is applied. The overall geometric accuracy requirement is stated to be better than 20m RMSE in each direction with respect to the European Land Cover dataset Image2000 (EU25) and USGS ETM+ Land Cover dataset (neighboring countries). For SPOT4/5 the Line-of-Sight vector is derived from continuous measurements of the state vectors and attitude parameters as well as the calibrated camera model provided by SpotImage in DIMAP format. For IRS-P6 LISS III the RPCs (Rational Polynomial Coefficients) serve as orientation input, which are provided by Euromap as a Universal Sensor Model in the OrthoKit format. Further input for the ortho-rectification is – in case of DLR – the European wide digital elevation model (DEM) from SRTM-C band Version 2 of NASA, improved by using inputs from MONAPRO, SRTM-X band DEM and GLOBE within a fusion process using accuracy layers for the different DEM databases and – in case of METRIA – other special DEM databases described in the report. In order to achieve the required geometric accuracy of 20m RMSE, ground control points (GCPs) are automatically (via image matching between the Image2000 / USGS Land Cover dataset and the new satellite scenes) and/or manually determined to improve the geometric accuracy of the orthoimages. From these derived GCPs, corrections of the orientation for SPOT4/5 and affine transformation parameters of the RPC for IRS-

 <p>METRIA</p>  <p>INGÅR I LANTMÄTERIET</p>	<h1>Image2006</h1>	<p><i>GMES Fast Track Land Service 2006-2008 Orthorectification of SPOT and IRS-P6 products</i></p> <p>Doc. No.: <i>Image2006</i></p> <p>Issue: <i>1.0</i></p> <p>Date: <i>12th May 2009</i></p> <p>Page: <i>16</i></p>
---	--------------------	--

P6 LISS III are derived. Quality assessment is based on ICPs (Independent Control Points), from which mean RMSE values for each scene and whole countries are derived or from which residual plots are produced.

  		<p style="text-align: center;"><i>GMES Fast Track Land Service 2006-2008 Orthorectification of SPOT and IRS-P6 products</i></p> <p>Doc. No.: <i>Image2006</i></p> <p>Issue: <i>1.0</i></p> <p>Date: <i>12th May 2009</i></p> <p>Page: <i>17</i></p>
---	---	--

5. Satellite Images

The reception of products from the SPOT-4/SPOT-5 HRVIR/HRG instruments in Level1A and IRSP6 LISS-III Level 1 making up two full European coverages (38 countries) and acquired in the reference year 2006 (+/- 1 year) are (mostly) based of complete country packages. The main specifications of the satellite images used are summarized in Table 5-1

Sensor	GSD (resolution) at nadir / sea level	Wavelength (bands) Green / Red / NIR / SWIR	Image Size at nadir view / sea level	Off-nadir capability
SPOT 4 HRVIR	20 m	500 – 590 nm 610 – 680 nm 780 – 890 nm 1580 – 1750 nm	60 x 60 km ²	Up to 30°
SPOT 5 HRG	10 m	495 – 605 nm 617 – 687 nm 780 – 893 nm 1545 – 1750 nm	60 x 60 km ²	Up to 30°
IRS-P6 LISS III	23.5 m	520 – 590 nm 620 – 680 nm 770 – 860 nm 1550 – 1700 nm	142 x 141 km ²	nadir

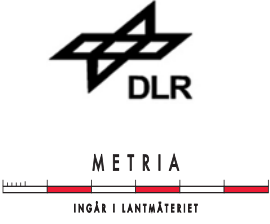

Table 5-1 Sensor systems

SPOT 4 HRVIR , SPOT 5 HRG

The delivered SPOT 5 HRG Level 1A and SPOT 4 HRVIR L1A product consists of the image data in standard GeoTIFF format and the metadata in DIMAP format [ID-05]. The following information was extracted for each image from the XML ancillary file for further processing:

- Satellite ephemeris data containing position and velocity measured by the DORIS system every 30 seconds with respect to the ITRF90 (International Terrestrial Reference Frame 1990) system during the data take and at least four times before and after image data acquisition
- Attitude data with respect to the local orbit coordinate frame measured by gyros and the star tracker unit with 8Hz; these data are already corrected for several effects (RD-30)
- Look direction table for the 3000/6000 CCD elements expressed within the sensor coordinate frame
- Data used for time synchronization like line sampling period and scene center time.

According to the „SPOT Satellite Geometry Handbook“ ID-05, Lagrange interpolation of the ephemeris data (satellite position and velocity w.r.t. ITRF90 datum) and linear interpolation of the attitude data (Euler angles w.r.t. orbit coordinate frame) are recommended to calculate the exterior orientation for each scan line using scene center time and sampling period for synchronization. More information on Spot can be found in [ID-05][RD-2][RD-3][RD-22][RD-30].

		<p style="text-align: center;"><i>GMES Fast Track Land Service 2006-2008 Orthorectification of SPOT and IRS-P6 products</i></p> <p>Doc. No.: <i>Image2006</i></p> <p>Issue: <i>1.0</i></p> <p>Date: <i>12th May 2009</i></p> <p>Page: <i>18</i></p>
---	---	--



IRS P6 LISS III

All IRS products have been delivered as OrthoKits, including GeoTIFFs and RPC files, and as Super Structure BSQ products. Generated from System Corrected full scenes. OrthoKit products are path oriented System Corrected products, in UTM projection with WGS84 geodetic datum, using cubic convolution resampling in Super Structure BSQ format [ID-06].

The OrthoKit is processed from path oriented System Corrected products in Super Structure BSQ format, following an image geometry reconstruction algorithm.

The OrthoKit consists of band separated GeoTIFF files, which are directly converted from the Super Structure image files without any geometric or radiometric processing, and text files holding the Rational Polynomial Coefficients (RPC) of the camera model. In order to achieve compatibility with existing COTS software, each GeoTIFF file is accompanied by an RPC file. The OrthoKit is available for full scenes only.

The system correction includes the radiometric and geometric correction of the data. The Super Structure BSQ format is described in ID-06.

		<p style="text-align: center;"><i>GMES Fast Track Land Service 2006-2008 Orthorectification of SPOT and IRS-P6 products</i></p> <p>Doc. No.: <i>Image2006</i></p> <p>Issue: <i>1.0</i></p> <p>Date: <i>12th May 2009</i></p> <p>Page: <i>19</i></p>
--	---	--

6. Methodology

For the countries above 60° Latitude the orthorectification of the image scenes are subcontracted to the Swedish company METRIA. Therefore two different methodologies – processing systems at DLR and METRIA – for the data evaluation and product generation exist, which are described in the following chapters.

6.1 Methodology of DLR

This section describes in comprehensive manner the DLR methodology of the automatic orthorectification chain as well as its limitations in problematic cases. Quality assessment is based on automatically extracted ICPs, from which mean RMSE values for each scene and whole countries are derived or from which residual plots are produced. It also describes the H/W infrastructure established for this demanding task as well as the S/W environment, which uses a MySQL database for the administration of the huge amount of data as well as to organize the parallel processing and a web-based user interface (GUI) to support manual data evaluation, job control and quality control tasks. For S/W development and generic image processing the DLR in-house developed Image Processing System XDibias is used.

For the orthorectification process two methods have to be used depending on the metadata delivered by the image provider SpotImage for SPOT data and Euromap for IRS-P6 data. The methods used are

- Direct Georeferencing (DG) for SPOT4 HRVIR and Spot 5 HRG
- Rational Polynomial Functions (RPF) for IRS-P6 LISS III.

For SPOT4/5 the Line-of-Sight vector is derived from continuous measurements of the state vectors and attitude parameters as well as the calibrated camera model provided by SpotImage. For IRS-P6 LISS III the RPCs (Rational Polynomial Coefficients) serve as input, which is provided by Euromap (Universal Sensor Model). Further input is the European wide digital elevation model (DEM) from SRTM-C band Version2 of NASA, improved by using inputs from MONAPRO and SRTM-X band DEM within a fusion process. In order to achieve the required accuracy of 20m RMSE, ground control points (GCPs) are automatically extracted via image matching between the Image2000 / USGS Land Cover dataset and the satellite scenes, which have to be ortho-rectified. From these automatically extracted GCPs and ICPs, corrections of the exterior orientation for SPOT4/5 and of the RPC for IRS-P6 LISS III (affine transformation) are derived, which are used for the production of high quality ortho-images.

In the following sections these methods are shortly described. A more detailed description can be found in [RD-1] [RD-4] [RD-5] [RD-6][RD-13][RD-33].

6.1.1 Orthorectification by Direct Georeferencing

The technique of Direct Georeferencing (DG) is based on a Line-of-Sight (LoS) model which extensively uses on-board measurements like Star Tracker Systems (STS) and Inertial Measurement Units (IMU) combined by Kalman filtering for the attitude determination and high precision orbit determination (position and velocity) like GPS (Global Positioning System) or DORIS (Doppler Orbitography and Radiopositioning Integrated by Satellite). The interior orientation is taken into account by look direction vectors derived from laboratory and/or in-flight geometric calibration. The different steps of orthorectification are illustrated in Figure 6-1

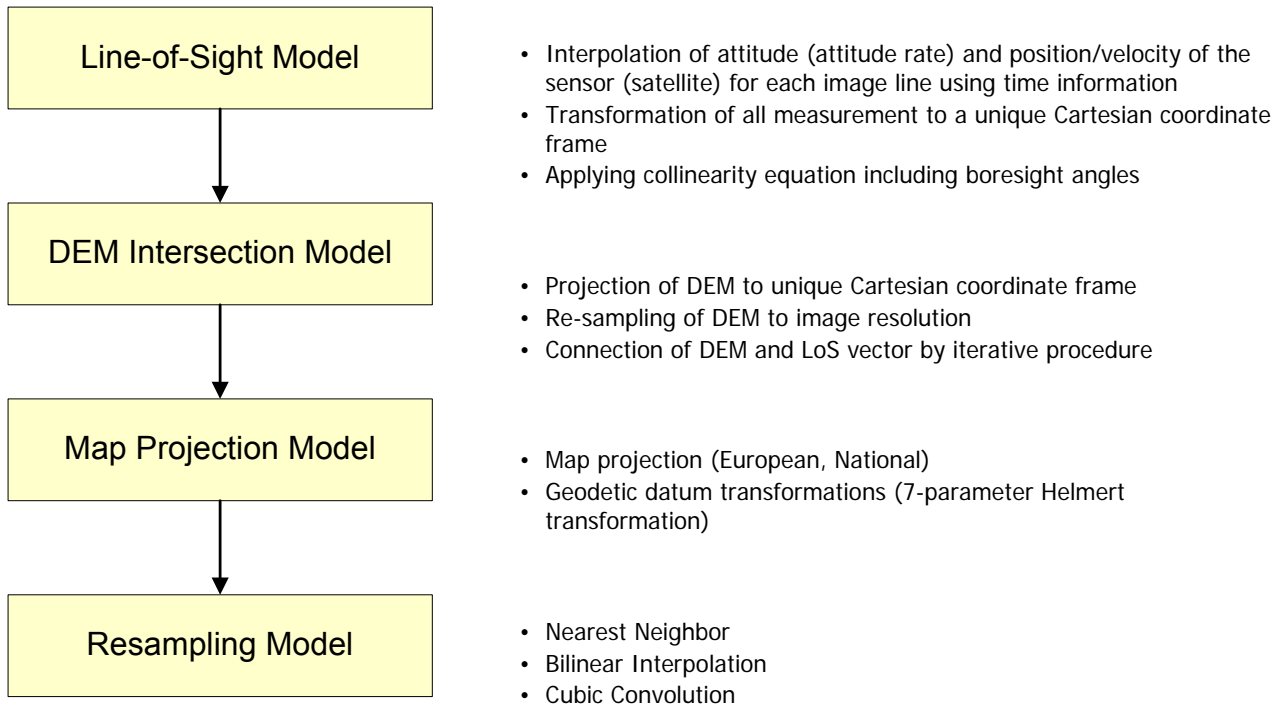

Figure 6-1 Levels of Orthorectification

Line-of-Sight Model

The basis for all direct georeferencing formulas is the collinearity concept, where the coordinates of an object point \mathbf{r}^m expressed in any earth bound mapping coordinate frame (index m used for the unique mapping coordinate frame) are related to image coordinates \mathbf{r}^{sensor} derived from the measured pixel position in the sensor's coordinate frame. The concept of Direct Georeferencing is shown in Figure 6-2

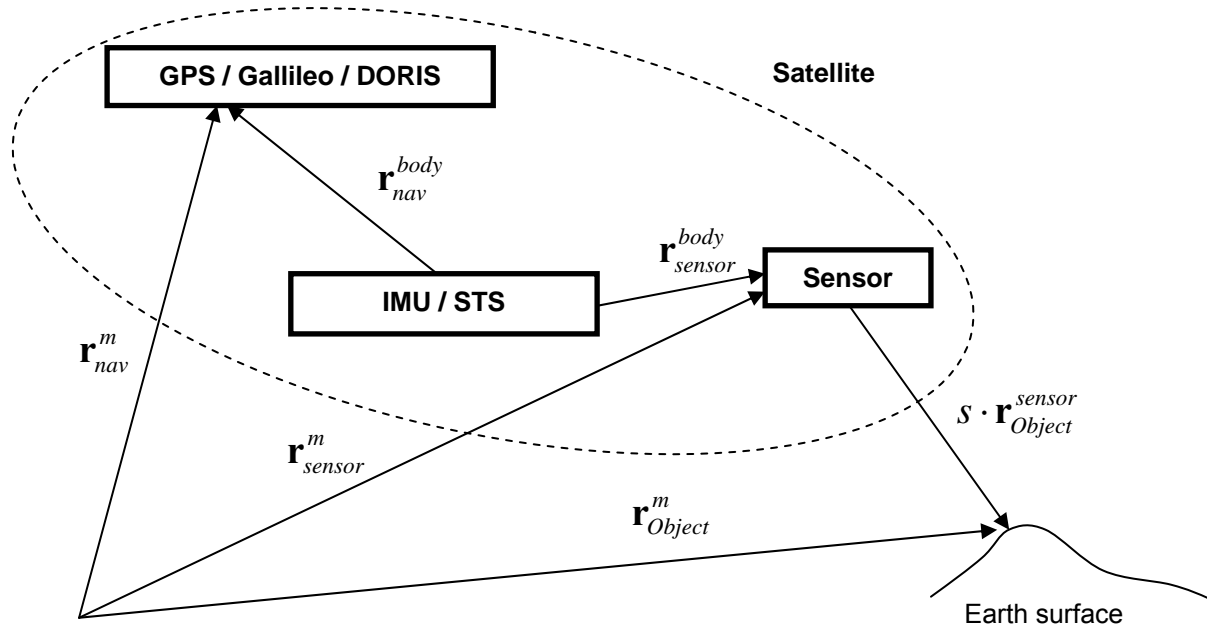

Figure 6-2 Concept of Direct Georeferencing (Line-of-Sight Model)

The rigorous relationship between 2D image coordinates and 3D object coordinates is given by



$$\mathbf{r}_{object}^m = \mathbf{r}_{sensor}^m + S \cdot \mathbf{R}_{body}^m \cdot \mathbf{R}_{sensor}^{body} \cdot \mathbf{r}_{object}^{sensor} \quad 6.1.1-1$$

where $\mathbf{R}_{sensor}^{body}$ denotes the rotation around the angles $\boldsymbol{\varepsilon} = (\varepsilon_1, \varepsilon_2, \varepsilon_3)$ from the sensor to the body coordinate frame (boresight alignment), which has to be calibrated, and \mathbf{R}_{body}^m denotes the rotation around the angles $\boldsymbol{\psi} = (\omega, \varphi, \kappa)$ from the body to a mapping coordinate frame, which is derived from the angular measurements. The position of the sensor projection centre

$$\mathbf{r}_{sensor}^m = \mathbf{r}_{nav}^m - \mathbf{R}_{body}^m \cdot \mathbf{r}_{nav}^{body} + \mathbf{R}_{body}^m \cdot \mathbf{r}_{sensor}^{body} \quad 6.1.1-2$$

is calculated from the measured position \mathbf{r}_{nav}^m reduced by pre-mission measured or in-flight calibrated lever arm values \mathbf{r}_{nav}^{body} from the body frame origin to the measured position and $\mathbf{r}_{sensor}^{body}$ from the body frame origin to the sensor projection centre, both expressed in the body coordinate frame. For single

¹ The lower indices of vectors (bold lower case letters, for example: \mathbf{r} , \mathbf{a} , ...) indicate the position of the points, whereas the upper indices denote the co-ordinate frame in which the vector is measured. Missing lower indices denote an arbitrary vector. The notation of the indices of transformation matrices (bold capital letter, for example: \mathbf{R} , \mathbf{T} , ...) indicates the transformation direction where the lower index represents the source system and the upper index the destination system. Missing indices denote an arbitrary transformation matrix.

 		<p style="text-align: center;">GMES Fast Track Land Service 2006-2008 Orthorectification of SPOT and IRS-P6 products</p> <p>Doc. No.: <i>Image2006</i></p> <p>Issue: <i>1.0</i></p> <p>Date: <i>12th May 2009</i></p> <p>Page: <i>22</i></p>
--	---	---

imagery the scale factor s is determined by the intersection of the sensor pointing direction with a geometric description of the earth or a given DEM expressed in the mapping coordinate frame.

DEM intersection model

The terrain displacements are taken into account using a Digital Elevation Model (DEM), which can be a surface model (DSM) or a terrain model (DTM). Geoid heights are transformed to ellipsoid height using the Earth Gravity Model EGM96. First the DEM is resampled (bi-linear interpolation) to the resolution of the input image within local topocentric Cartesian coordinate frame, which serves as unique object coordinate frame (rigorous mathematics). Second the intersection between the LoS vector and the resampled DEM is determined by an iterative process which results in a 3D point in object space for each image pixel.

Map Projection Model

The reconstructed 3D object points, given in the unique Cartesian coordinate frame, are transformed to the desired map projection, where the resampling is performed. About 30 different map projection systems and a lot of predefined geodetic datum parameter sets (>100) as well as definable datum parameter sets (including 40 ellipsoids) are supported for the ortho image generation.

Resampling Model

Finally the orthoimage is resampled to the desired resolution using Nearest Neighbour, bilinear interpolation or cubic convolution technique. For Image2006 cubic convolution is the preferred method.

Model Parameter Estimation (inverse modelling)





Using Ground Control Information (GCPs) a refinement of model parameters by iterative least squares adjustment can be performed in order to achieve an improvement of the geometric accuracy of the ortho images. For Direct Georeferencing the parameters of the LoS model are improved by GCP information (for example in the case of Spot 5, which utilizes the DORIS system to achieve high accuracy position determination of < 1m, attitude restitution remains the main task). Image-to-image matching techniques can be used to generate – in combination with interpolated DEM values – automatically GCPs. Manual GCP measurement can be a further option.

Eliminating the scale factor s and assuming that the exterior orientation is determined by measurements, the relation between image space and object space coordinates is after rearranging the collinearity equation 6.1.1-1 of the form (assuming in this case only estimations of boresight angles)

$$\begin{aligned} x^s &= f_x(\mathbf{r}^m; \boldsymbol{\varepsilon}) \\ y^s &= f_y(\mathbf{r}^m; \boldsymbol{\varepsilon}) \end{aligned} \tag{6.1.1-3}$$

In equation 6.1.1-3 the functions $f_{x/y}$ depend also on the three unknown angles $\boldsymbol{\varepsilon}$. Introducing the image coordinates x_{GCP}^s, y_{GCP}^s (measured with sub-pixel accuracy) and the object space coordinates \mathbf{r}_{GCP}^m of the GCPs into the linearized equation 6.1.1-3 leads to

$$x_{GCP}^s - x^s \Big|_{GCP} = \sum_k \left. \frac{\partial f_x}{\partial \varepsilon_k} \right|_{GCP} d\varepsilon_k$$

  		<p style="text-align: center;">GMES Fast Track Land Service 2006-2008 Orthorectification of SPOT and IRS-P6 products</p> <p>Doc. No.: <i>Image2006</i></p> <p>Issue: <i>1.0</i></p> <p>Date: <i>12th May 2009</i></p> <p>Page: <i>23</i></p>
---	---	---

$$y_{GCP}^s - y^s \Big|_{GCP} = \sum_k \frac{\partial f_y}{\partial \varepsilon_k} \Big|_{GCP} d\varepsilon_k \quad 6.1.1-4$$

in which the functions $f_{x/y}$ are evaluated at the GCPs using interpolated values of the exterior orientation. For a set of GCPs (min. 2) the system of linear equations is solved by iterative least squares adjustment. The estimated angles ε describe the relative orientation between sensor and body coordinate frame, assuming a constant behavior during the data acquisition time.

Processing of Spot 4 HRVIR and Spot 5 HRG scenes

In case of Spot 4/5 the functional model of equation 6.1.1-1 is used to describe the relation between the 3D object point $\mathbf{r}^m = (x^m, y^m, z^m)^T$ expressed in an earthbound mapping coordinate frame m (the mapping coordinate frame m is a local topocentric system LTS with a fundamental point near the center of the image) with the coordinates $\mathbf{r}^s = (x^s, y^s, -c)^T$ of the 2D image space derived from the pixel number i in the image line by $\mathbb{N} \rightarrow \mathbb{R}^3: i \rightarrow \mathbf{r}^s = (\tan(\Psi_x)_i, \tan(\Psi_y)_i, -1)^T$, with $(\Psi_x)_i$ and $(\Psi_y)_i$ the tabulated values of the look direction and the normalized focal length $c=1$, expressed in the sensor's coordinate frame (x^s : along track; y^s : across track left; z^s : up).

$$\mathbf{r}^m = O_{ECEF}^m(\mathbf{r}_s^{ECEF}) + S \cdot \mathbf{R}_b^m \cdot \mathbf{R}_s^b \cdot \mathbf{r}^s \quad 6.1.1-5$$

The operator O_{ECEF}^m transforms the interpolated positions of the satellite mass centre, expressed in the ITRF90 earth centered earth fixed (ECEF) Cartesian frame, to the mapping coordinate frame (translation offsets between satellite mass centre and sensor projection centre are neglected). The matrix \mathbf{R}_s^b describes an additional rotation around the angles $\varepsilon = (\varepsilon_1, \varepsilon_2, \varepsilon_3)$ from the sensor to the body coordinate frame individually for each camera and can be determined by ground control information (GCPs). This rotation matrix is called boresight alignment matrix and is set to the unit matrix if no GCPs are used. This rotation matrix can be assumed to be constant for each single scene. The transformation from the body coordinate frame b to the mapping coordinate frame m (LTS) is depended on the time (t) when the image line is recorded – and is modeled as follows





$$\mathbf{R}_b^m(t) \equiv \mathbf{R}_{ECEF}^{LTS} \cdot \mathbf{R}_{Orbit}^{ECEF}(t) \cdot \mathbf{R}_{Body}^{Orbit}(t) \quad 6.1.1-6$$

where the orthogonal transformation of the rotation

$$\mathbf{R}_{Body}^{Orbit} = \mathbf{R}_x(\alpha_1) \cdot \mathbf{R}_y(\alpha_2) \cdot \mathbf{R}_z(-\alpha_3) \quad 6.1.1-7$$

is composed by the measured attitude Euler angles $\alpha = (\alpha_1, \alpha_2, \alpha_3)$ with respect to the orbit coordinate frame and the direction cosine matrix

$$\mathbf{R}_{Orbit}^{ECEF} = \left(\begin{array}{c} \left(\frac{(\mathbf{r}_s^{ECEF} \times \mathbf{v}_s^{ECEF}) \times \mathbf{r}_s^{ECEF}}{|\mathbf{r}_s^{ECEF} \times \mathbf{v}_s^{ECEF}| \times |\mathbf{r}_s^{ECEF}|} \right) \cdot \left(\frac{(\mathbf{r}_s^{ECEF} \times \mathbf{v}_s^{ECEF})}{|\mathbf{r}_s^{ECEF} \times \mathbf{v}_s^{ECEF}|} \right) \cdot \left(\frac{\mathbf{r}_s^{ECEF}}{|\mathbf{r}_s^{ECEF}|} \right) \\ \left(\frac{(\mathbf{r}_s^{ECEF} \times \mathbf{v}_s^{ECEF}) \times \mathbf{r}_s^{ECEF}}{|\mathbf{r}_s^{ECEF} \times \mathbf{v}_s^{ECEF}| \times |\mathbf{r}_s^{ECEF}|} \right)' \cdot \left(\frac{(\mathbf{r}_s^{ECEF} \times \mathbf{v}_s^{ECEF})}{|\mathbf{r}_s^{ECEF} \times \mathbf{v}_s^{ECEF}|} \right)' \cdot \left(\frac{\mathbf{r}_s^{ECEF}}{|\mathbf{r}_s^{ECEF}|} \right)' \end{array} \right) \quad 6.1.1-8$$

  		<p style="text-align: center;">GMES Fast Track Land Service 2006-2008 Orthorectification of SPOT and IRS-P6 products</p> <p>Doc. No.: <i>Image2006</i></p> <p>Issue: <i>1.0</i></p> <p>Date: <i>12th May 2009</i></p> <p>Page: <i>24</i></p>
---	---	---

is build by the unit orthogonal basis vectors, spanning the orbit frame, with \mathbf{r}_s^{ECEF} the interpolated satellite position vector and \mathbf{v}_s^{ECEF} the interpolated satellite velocity expressed in the ITRF90 earth centered earth fixed (ECEF) coordinate frame. The definition of the orbital co-ordinate frame is as follows:

- Origin at the position of the barycenter of the satellite
- Z^{Orbit} pointing from the earth center of mass (origin of ECEF co-ordinate frame) to satellite center of mass
- Y^{Orbit} directed along the normal of the actual orbital plane, which is pointing to the actual angular momentum of the satellite motion in orbit
- X^{Orbit} completes the right handed triad

The ortho image processor ORTHO of DLR is based on this Direct Georeferencing (DG) method using a rigorous physical Line-of-Sight (LoS) model, which describes the mapping from 2D image space to 3D object space. Therefore several measured parameters serve as input for the processor. These are

- **State vectors (satellite position and velocity):** for SPOT4/5 the measured state vectors, which are given w.r.t. ITRF89, are interpolated for each image line using Lagrange interpolation technique.
- **Attitude values:** for SPOT4/5 the measured attitude angles, which are given w.r.t. the orbit coordinate frame, are linearly interpolated for each image line. For SPOT5 the combined attitude measurements (Kalman Filter) by a star-tracker and gyro are used, whereas for SPOT4 the gyro angle rate measurements are integrated using initial attitude measurements.
- **Interior orientation (sensor model):** for SPOT4/5 these are measured look directions for each pixel in the image line (laboratory and/or refinements by self-calibration)



Using Ground Control Information (GCPs) a refinement of parameters can be performed. The satellite systems of SPOT4/5 with highly accurate state vectors using the DORIS system the boresight alignment angles (rotational offsets between camera and attitude measurement unit) and/or angle offsets are estimated for each scene.

6.1.2 Orthorectification by Rational Polynomial Functions

The IRS-P6 Liss III scenes of the project are provided by Euromap company. Exterior and interior orientation as known directly after image acquisition (accuracy in the range of a few hundred meters) are implicitly encoded in form of rational polynomial functions (RPF) using third order polynomials for nominator and denominator (80 coefficients). This Universal Sensor Model (USM) provides the transformation of object space coordinates to image space coordinates. RPF are provided in standard format like those used for IKONOS-2 and QuickBird images (see e.g. [RD-32]). Each of the RPF for row and column in equation (6.1.2-1) is given via a ratio of 2 polynomials of third order in normalized λ , φ , and h with 20 coefficients.

$$\begin{aligned} r &= rpf_r(\lambda, \varphi, h) \\ c &= rpf_c(\lambda, \varphi, h) \end{aligned} \tag{6.1.2-1}$$

where r/c are row and column coordinates of the image and λ , φ , and h are longitude, latitude and ellipsoidal height in geographic coordinates of WGS84 datum.

		<p style="text-align: center;">GMES Fast Track Land Service 2006-2008 Orthorectification of SPOT and IRS-P6 products</p> <p>Doc. No.: <i>Image2006</i> Issue: <i>1.0</i> Date: <i>12th May 2009</i> Page: <i>25</i></p>
--	---	--

For numerical reasons the calculation is actually based on normalized variables restricted to the interval $[-1,+1]$ by choosing appropriate values for offset and scale which are provided together with the coefficients of the polynomials:

$$r_n = \frac{r - r_0}{r_s}, \quad c_n = \frac{c - c_0}{c_s}, \quad v = \frac{\lambda - \lambda_0}{\lambda_s}, \quad u = \frac{\varphi - \varphi_0}{\varphi_s}, \quad w = \frac{h - h_0}{h_s} \quad \text{offset : } r_0, \dots, h_0, \quad \text{scale : } r_s, \dots, h_s$$

6.1.2-2

The normalized values r_n and c_n of the image coordinates are given as ratio of third order polynomials in u , v and w :

$$r_n = \frac{a_1 + a_2v + a_3u + a_4w + \dots + a_{20}w^3}{1 + b_2v + b_3u + b_4w + \dots + b_{20}w^3}, \quad c_n = \frac{d_1 + d_2v + d_3u + d_4w + \dots + d_{20}w^3}{1 + e_2v + e_3u + e_4w + \dots + e_{20}w^3}$$

6.1.2-3

Because of the low absolute accuracy of the original RPF these have to be corrected via ground control with DLR software RPPCORRECTION. An affine transformation is estimated by least squares adjustment via the GCP derived from image matching between coarsely registered satellite scene and the reference scene. The corrected image coordinates are calculated based on this affine transformation and the RPF:

$$\begin{aligned} row &= a_0 + a_1rpf_r + a_2rpf_c \\ col &= b_0 + b_1rpf_r + b_2rpf_c \end{aligned}$$

6.1.2-4

where rpf_r and rpf_c are the originally provided rational polynomial functions

After the calculation of the position in the input satellite image the grey values for the multi-channel orthoimage are retrieved via an interpolation scheme. In this project bi-cubic spline interpolation is used.

Using these equations and a powerful tool for transformations between datum/projection combinations orthoimages for a large spectrum of datum/projection combinations can be calculated by DLR software RPCORTHO. Inputs to this software are:





- IRS-P6 Liss III scene and RPF functions with affine correction (if available)
- Target datum/projection (e.g. country specific or European datum/projection) of the orthoimage
- Digital elevation model (normally given in a different datum/projection combination)

More details on RPF processing can be found in RD-16 and RD-17.

6.1.3 Automatic Processing Chain



Figure 6-3 illustrates the overall operational processing chain, which is fully automatic, except for the manual process of the internal quality control [see also RD-33]. The automatic processing steps are:

- **Transcription:** The transcription system reformats the original images to an internal image format and extracts from the metadata the information needed for further processing (internal level 1 product). For SPOT 4/5 images the ephemeris data (position and velocity) and the attitude measurements are interpolated for each image line based on synchronization information. The interior orientation given by look direction angles is evaluated for each pixel in the scan line. For

  		<p style="text-align: center;"><i>GMES Fast Track Land Service 2006-2008 Orthorectification of SPOT and IRS-P6 products</i></p> <p>Doc. No.: <i>Image2006</i></p> <p>Issue: <i>1.0</i></p> <p>Date: <i>12th May 2009</i></p> <p>Page: <i>26</i></p>
---	---	--

IRS-P6 images the Rational Polynomial Coefficients (RPCs) are extracted from the OrthoKit product, which contains human readable dumps (text format) of the Super Structure files.

- **DEM & Reference Tile Generation:** Using the provided coarse image corner coordinates congruent tiles from the DEM database and from the reference image database are extracted and mosaicked with a margin of about 2km due to the pointing knowledge of the sensor.
- **Coarse registration:** Also based on the four image corner coordinates a coarse rectification using simple affine transformation is performed. The coarsely registered images serve as input for an automatic image matching with the reference image tiles.
- **Automatic tie point generation by matching:** In order to automatically extract GCPs/ICPs (Ground Control Points / Independent Control Points) from the reference image a hierarchical intensity based matching is performed [RD-6] [RD-7][RD-8][RD-9]. The matching process uses a resolution pyramid to cope with large image differences between the reference and the coarse registered image. Based on the Foerstner interest operator pattern windows are selected in one of the images and located with an accuracy of about one pixel in the other image via the maximum of the normalized correlation coefficients computed by sliding the pattern area all over the search area. The search areas in the matching partner image are determined by estimation of local affine transformations based on already available tie points in the neighborhood (normally from a coarser level of the image pyramid). The approximate tie point coordinates are then refined to sub-pixel accuracy by local least squares matching. The number of points found and their final (sub-pixel) accuracy achieved depend mainly on image similarity and decrease with time gaps between imaging. Only points with high correlation and quality figure are selected as tie points including cross checking by backward matching of all found points.
- **GCP/ICP Generation:** The tie points – or manual measured points – belonging to the reference image are supplemented to 3D object points by interpolated DEM values. Finally the set of tie points is divided into GCPs for an improvement of the orthorectification and ICPs for quality assessment. The selection of GCPs is based on the requirement of equally distributed points over the scene with high quality figure.
- **Parameter estimation:** Within the next processing step improved parameters for the orthorectification are estimated using GCP information. For SPOT 4/5, which utilizes the DORIS (Doppler Orbitography and Radiopositioning Integrated by Satellite) system to achieve high accuracy orbit determination (position accuracy < 1m), attitude restitution remains the main task. For SPOT 4 especially the initial attitude values and for SPOT 5 the thermal affected misalignment between sensor and body coordinate frame are the major causes of pointing errors. For IRS-P6 LISS III a RPC correction via affine transformation is performed. Within the Least Squares Adjustment simple, iterative blunder detection is integrated, which eliminates step by step GCPs with a residual greater than 2 pixels starting with the bottom quality GCP.
- **Geocoding:** For SPOT 4/5 scenes the physical model of Direct Georeferencing (DG) and for IRS-P6 scenes the rational polynomial camera model (RPC) is applied to produce orthoimages with

		<p style="text-align: center;"><i>GMES Fast Track Land Service 2006-2008 Orthorectification of SPOT and IRS-P6 products</i></p> <p>Doc. No.: <i>Image2006</i> Issue: <i>1.0</i> Date: <i>12th May 2009</i> Page: <i>27</i></p>
--	---	--

25m resolution in European projection LAEA ETRS89 (Lambert Azimuthal Equal Area with European Terrestrial Reference System 1989 as geodetic datum) [ID-04] and with 20m resolution in National map projection different for each country. For the resampling process bi-cubic spline interpolation (a-factor = 0.66) is applied to achieve best image quality for thematic interpretation.

- **Quality control** can be separated into examination of correctness of the orthorectified images and completeness of the coverage and is partly based on the “Guidelines for Best Practice and Quality Checking of Ortho Imagery” [ID-04]. The results of the quality check are summarized in a Quality Assurance Record (QAR) and stored in a database. In case the geolocation accuracy requirement is not fulfilled or inconsistencies are detected GCPs are measured manually and the scenes are “checked in” for re-processing. The ***correctness check*** includes the following tasks:
 - Checking for equally distributed GCPs over the scenes
 - Checking of residual plots derived from the ICPs (residual vectors should not show systematic behavior)
 - Checking if RMS errors fulfill the requirement to be better than 20m in each direction
 - Visual checking of orthorectified image overlaid with re-projected reference image.
 - Visual checking of orthorectified image overlaid with neighbor scenes.
 - Visual checking of radiometric quality and cloud coverage of the orthorectified images
 - Visual checking of used DEM tiles (holes, artifacts) and used reference tiles (cloud coverage, radiometric quality, artifacts, geometric errors)

For the ***completeness check*** image mosaics of whole countries are generated (images with broad cloud coverage are stacked to the background). Using country frontier polygons the image mosaic is proved for a complete coverage of the country without any holes.

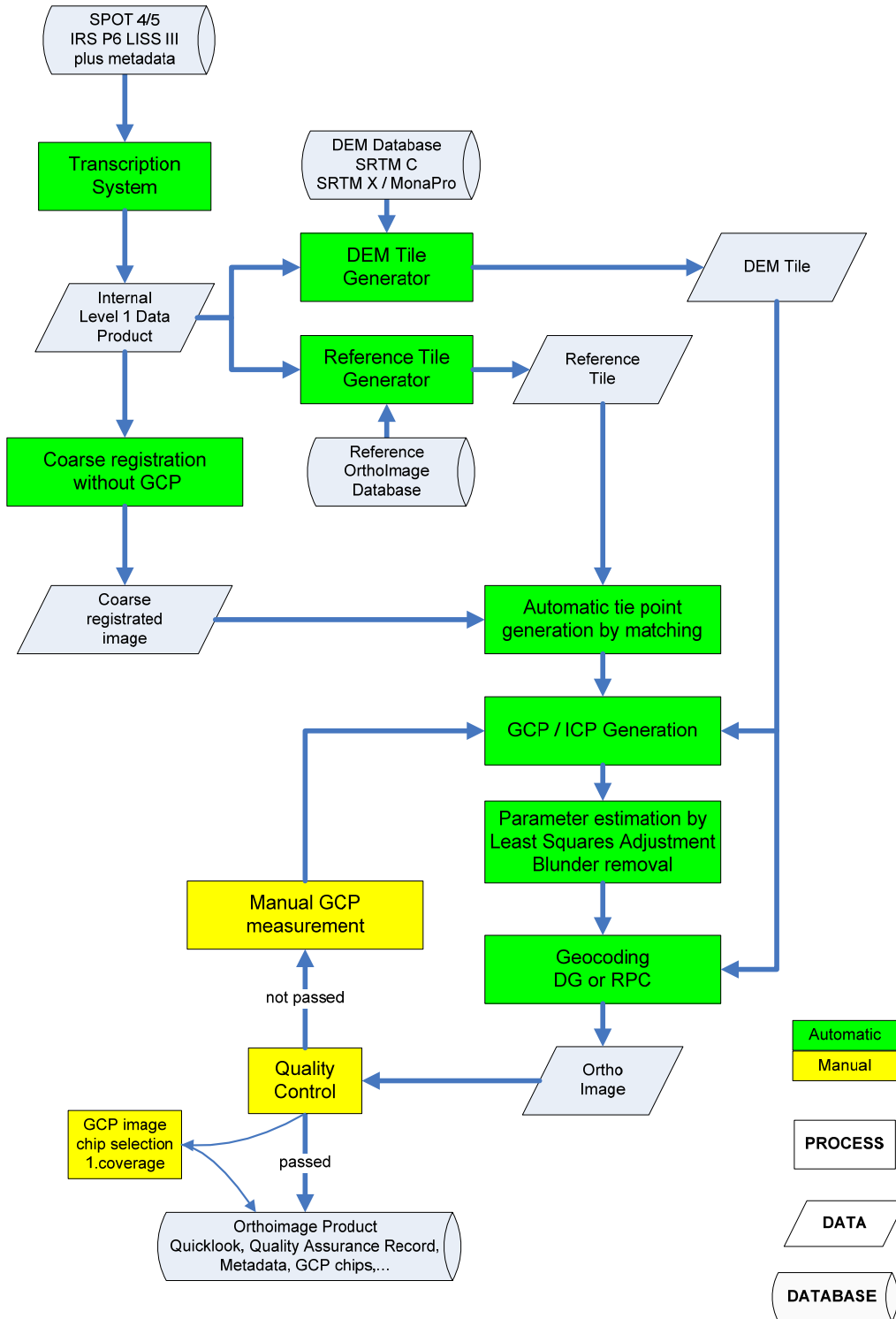



Figure 6-3 Operational automatic processing chain for orthoimage production and manual QC

		<p style="text-align: center;"><i>GMES Fast Track Land Service 2006-2008 Orthorectification of SPOT and IRS-P6 products</i></p> <p>Doc. No.: <i>Image2006</i> Issue: <i>1.0</i> Date: <i>12th May 2009</i> Page: <i>29</i></p>
--	---	--

The demanding task to process about 3800 scenes in a very short time frame requires fast and parallel processing. Table 6-1 shows the processing times in hours for the different subtasks:

Sub-task	IRS-P6	SPOT 4/5
Transcription, DEM & Reference tile generation, coarse rectification	0.2	0.1
Matching, GCP/ICP generation	2.2	0.3
Geocoding (National and European product) plus parameter estimation and re-projection of reference image	1.5	0.5
Quality control (manual)	~1.5	~1.0

Table 6-1 Throughput values in hours for one workstation

The maximum throughput of the whole processing system (10 desktop workstations occupied with 10 operators) including manual Quality Control is therefore for one **IRS-P6** scene about **0.5 h** and for one **SPOT** scene about **0.2 h**.

About 3-5% of the images have to be processed manually (additional GCP measurements) in cases the product does not pass the internal quality control.

6.1.4 Processing Infrastructure

For the huge amount of scenes to be processed in a very short time interval the S/W and the H/W must be suitable for parallel processing with the capability of reliable data storage.

The H/W consists of a passive and active cluster node – file servers replicated and synchronized via heartbeat – with two dual core Intel 5050 processors each, which are connected to a directly attached storage (RAID 5) of 2.7 Tbyte via fibre channel. For parallel processing 10 workstations are attached to the file server via 1Gbit Ethernet. The Linux 64bit CentOS 4.4 x86 serves as operating system (Figure 6-4).

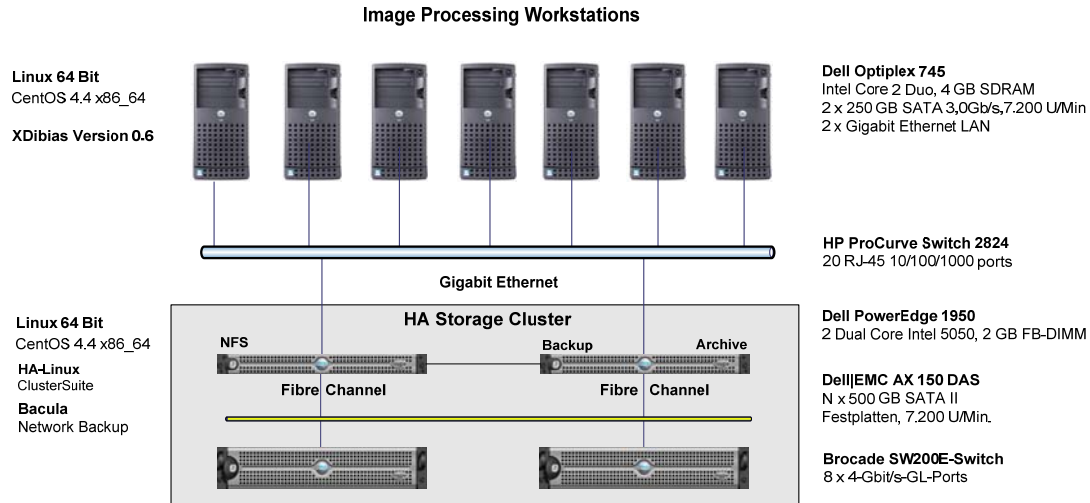

Figure 6-4 System Hardware for IMAGE2006

A permanent external monitoring process watches the condition of system resources – namely network connectivity, RAID status, CPU, memory, fan, power, storage resources and system processes – and reports fail functions and storage overflows via SMS and e-mail (Figure 6-5).

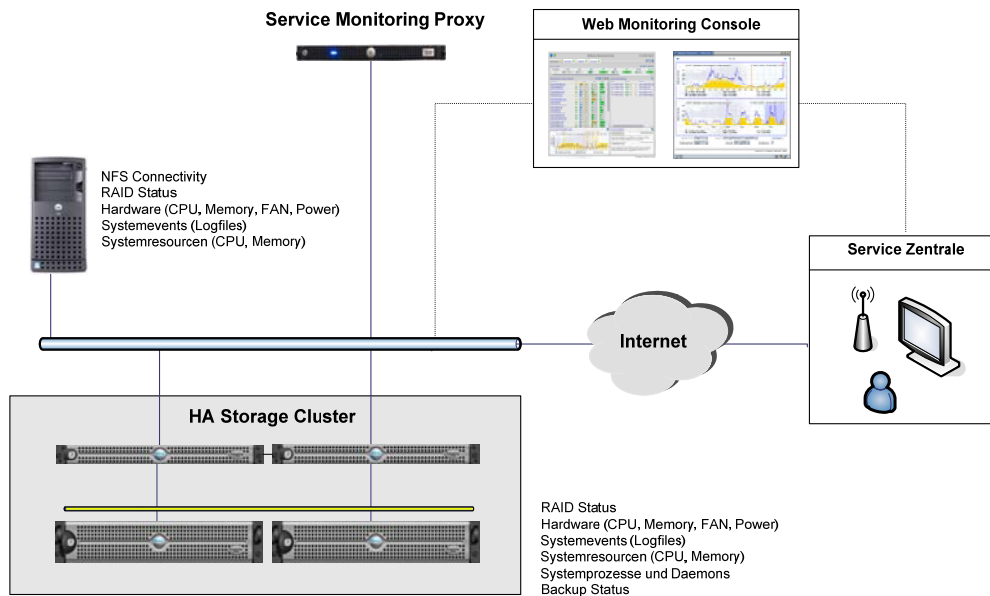

Figure 6-5 Monitoring concept of H/W and S/W for Image2006

The S/W front end consists of a web based interface for the administration of the image data and the different processing levels – namely imported, GCP/ICP generated, geocoded, quality controlled, completed, delivered – with a MySQL database in the background (Figure 6-6). The parallel processing is realized by an autonomous process queue distributing the jobs among the workstations. The different processing modules are assembled to S/W processors using higher level script languages. The whole processing chain is a DLR in-house development and therefore allows flexible reactions to fulfil (changing) requirements.

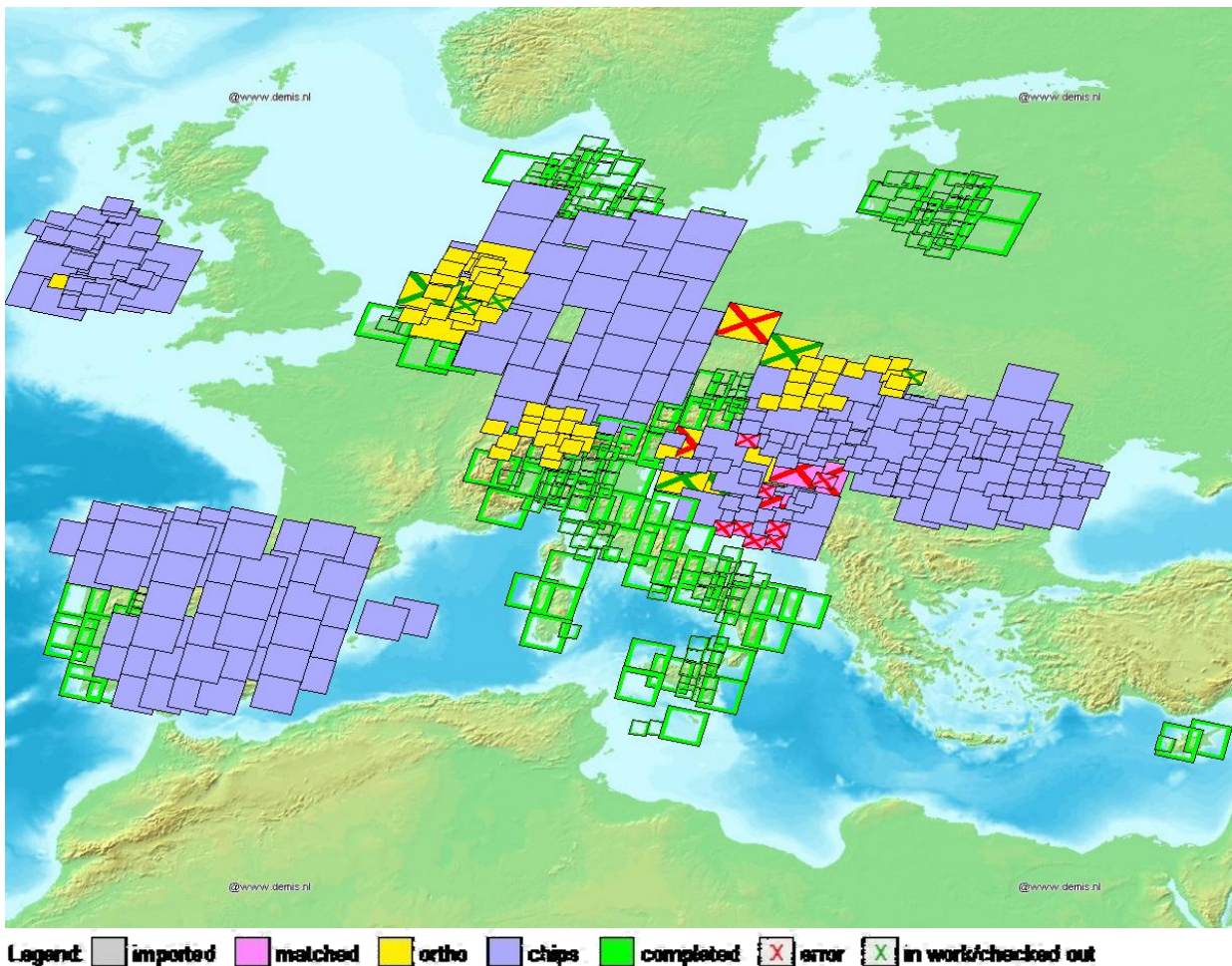
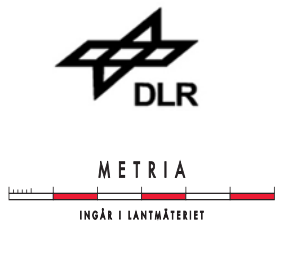

Figure 6-6 WEB based interface for image administration and processing (intermediate state)

6.1.5 Digital Elevation Model (DLR)

A European wide digital elevation model (DEM) serves as input for the processing chain. The DEM database is derived from SRTM-C band Version 2 of NASA and improved by using inputs from MONAPRO, GLOBE and SRTM-X band DEM within a fusion process [RD-31]. Parts of the DEM dataset are manually edited to remove blunder areas. The DEM is given in geographic projection (geodetic datum WGS84) with

	<h1>Image2006</h1>	<p style="text-align: center;"><i>GMES Fast Track Land Service 2006-2008 Orthorectification of SPOT and IRS-P6 products</i></p> <p>Doc. No.: <i>Image2006</i> Issue: <i>1.0</i> Date: <i>12th May 2009</i> Page: <i>32</i></p>
---	--------------------	--

1 arcsec planar resolution (~30m) with ellipsoid heights. Figure 6-7 shows the mosaic of the DEM tiles used at DLR. The DEM serves as input in order to perform terrain correction within the orthorectification process and to extract interpolated heights for the GCP chip database. According to the SoW the DEM database w42 developed and implemented at DLR is used for this purpose. The height accuracy (1σ) of the DEM is about 6m in flat areas and up to 30m in mountainous areas. In the Alps greater parts of MONAPRO and in East Turkey greater parts of GLOBE has to be used.

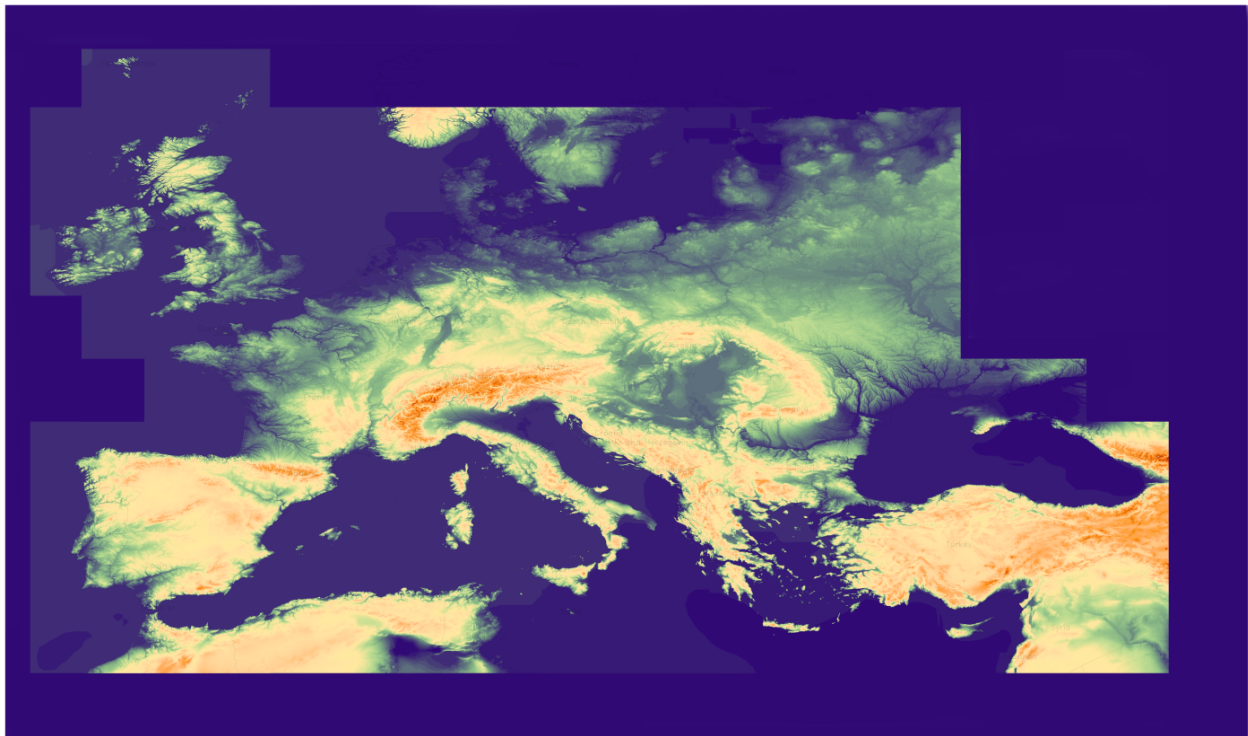
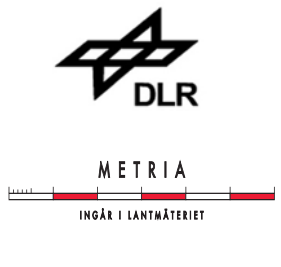



Figure 6-7 Digital Elevation Model DEM used at DLR for orthorectification

6.1.6 Reference Data Sets

For the countries, which took part in the IMAGE2000 project [ID-01], the absolute references are the orthorectified panchromatic images derived from Landsat 7 Enhanced Thematic Mapper ETM+ imagery given in geographic projection (WGS84) with a resolution of 0.000115° (~12m) and an accuracy of about 9-15m $RMSE_x$ and 7-18m $RMSE_y$ (except for Austria with 52m $RMSE_x$ and 27m $RMSE_y$) [ID-01]. For all other countries the USGS ETM+ Land Cover dataset given in UTM projection with a resolution of 28.5m and a global accuracy of about 50m $RMSE_{xy}$ serves as absolute reference. Additionally the accuracy of both reference data has been investigated using ground control information from superior quality in the region of southern Bavaria. Table 6-2 summarizes the quality assessment derived from 12 GCPs.

		<p style="text-align: right;"><i>GMES Fast Track Land Service 2006-2008 Orthorectification of SPOT and IRS-P6 products</i></p> <p>Doc. No.: <i>Image2006</i> Issue: <i>1.0</i> Date: <i>12th May 2009</i> Page: <i>33</i></p>
---	---	---

	RMSE _{x/y} [m]	Mean _{x/y} [m]	Sigma _{x/y} [m]
Image2000	15.6 / 13.2	2.9 / -6.2	15.4 / 11.7
USGS	30.6 / 21.2	28.9 / 17.6	10.1 / 11.8

Table 6-2 Absolute geolocation accuracy of reference images derived from 12 GCPs of superior quality in southern Bavaria

These results confirm the official accuracy specifications with slightly better values for the Image2000 land cover dataset in this region. A systematic error for the USGS land cover dataset can be obtained, but with similar standard deviations as for the Image2000 dataset.

6.1.7 Limitations and Experiences of Data Processing

The number of automatically derived ICPs (and GCPs) strongly depends on the similarity of the images having a time gap of 5-6 years. Especially agriculture areas show greater changes over the years, which reduce dramatically the amount of tie points. In the case of Romania with heavy flooding between the years 2000 and 2006 for some affected scenes less tie points can be found. Good candidates for image matching are arid areas like in Spain or mountainous areas with time constant sharp ridges.

For scenes containing only land areas of small extend (like scenes with islands) the image matching sometimes fails due to the image pyramid up to level 32. At this high pyramid levels small land areas vanish. In these cases manual GCP measurements have to be performed.

As stated before IMAGE2000 and USGS land cover datasets should be considered as absolute reference. These datasets contain systematic and local geometric distortions. The models and the parameter estimations used for the orthorectification process (DG and RPC) are not designed to handle such unrealistic errors in a rigorous manner. For example Figure 6-8 shows an ideal distribution of ICPs (and GCPs) over a SPOT scene with equally distributed residual vectors. In Figure 6-9, which represents a mountainous area in Austria, larger deviations can be obtained in the bottom-left part. This results, for example, from the mosaicking of orthorectified reference images with insufficient geometric accuracy.



METRIA



Image2006

GMES Fast Track Land Service 2006-2008
Orthorectification of SPOT and IRS-P6 products

Doc. No.: *Image2006*

Issue: *1.0*

Date: *12th May 2009*

Page: *34*

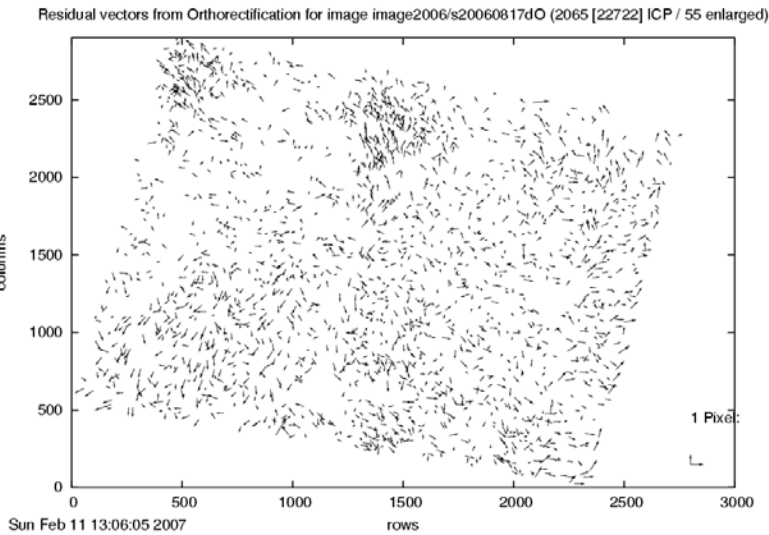

Figure 6-8 Deviations in pixel – factor 55 enlarged – of automatically determined ICPs from the reference image versus image coordinates of the orthorectified scene (SPOT 4) after correction with GCPs (RMSE_x=12.4m, RMSE_y=8.0m)

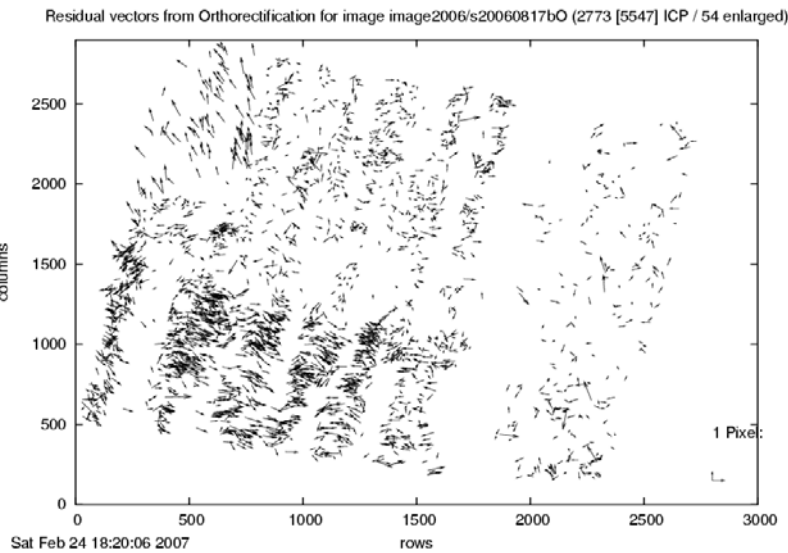
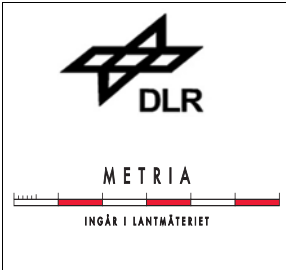



Figure 6-9 Deviations in pixel – factor 54 enlarged – of automatically determined ICPs from the reference image versus image coordinates of the orthorectified scene (SPOT 4) after correction with GCPs (RMSE_x=12.6m, RMSE_y=12.3m)

		<p style="text-align: center;"><i>GMES Fast Track Land Service 2006-2008 Orthorectification of SPOT and IRS-P6 products</i></p> <p>Doc. No.: <i>Image2006</i> Issue: <i>1.0</i> Date: <i>12th May 2009</i> Page: <i>35</i></p>
--	---	--

6.1.8 GCP Chip Selection Process

A GCP is a geographical object (e.g. center of a road crossing) for which the position in an image and the location on Earth is known with a certain accuracy. In order to be able to automatically locate such GCP in a sensor's imagery a database of GCP image chips has to be available. Such a database can be built up during the operation time of the sensor or stem from other sensors with comparable radiometric properties and geometric resolution. Elements of the database can be manually measured and/or can be established through automatic correlation processes of the current imagery with other images which are known to be already carefully registered to a map. The process of the GCP chip selection is as follows

- Automatic image matching between reference image and raw image in order to extract tie points with high quality figure (quality features are part of the tie points). The extracted tie points from the reference image are planar GCPs, which are also known in the raw image given in image coordinates (line / column). The accuracy using automatic matching techniques is about 0.2 pixel.
- Within the orthorectification process the tie points in the raw image are mapped to the European projection.
- Manual selection of suitable GCPs out from the set of points. The criteria of the GCP selection process are
 - Time invariance (e.g. road crossings)
 - Equally distributed
 - High quality figure (e.g. correlation coefficient)
 - High texture of the image chips
- Based on the mapped tie points image chips of size 101x101 pixels are extracted around the GCP from the orthorectified scene in European map projection.
- In order to get 3D GCPs the height information is extracted from the DEM by bi-linear interpolation.
- Generation of GCP image chips in PNG format. Figure 6-10 shows an example of a GCP image chip.

Additionally manual measurements are possible with sub pixel accuracy (typical plotting errors are half a pixel size).

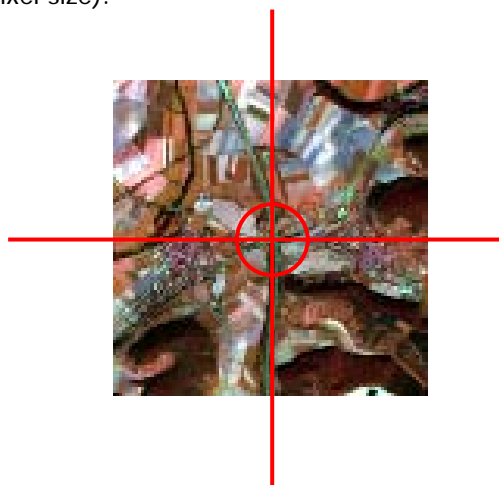

GCP chip naming convention [in meter resolution]:

<Easting>_<Northing>_<EllipsoidHeight>.png

Example: 4179645_2766680_385.png

Projection: LAEA-ETRS89

Resolution: 25 m

Chip size: 101 x 101 pixel

Channels: Green, Red, NIR (see Table 5-1)

Origin: Image2006 data set of first coverage and interpolated "best of" DEM

Accuracy: ~10m w.r.t. reference data (*as Image2006*)

Density: ~15 GCP chips @ 3600 km²

Total amount of GCP image chips EU38: 61053

Figure 6-10 GCP Chip Image

	<h1>Image2006</h1>	<p style="text-align: center;"><i>GMES Fast Track Land Service 2006-2008 Orthorectification of SPOT and IRS-P6 products</i></p> <p>Doc. No.: <i>Image2006</i> Issue: <i>1.0</i> Date: <i>12th May 2009</i> Page: <i>36</i></p>
---	--------------------	--

Some examples of GCP image chips are shown in Figure 6-11

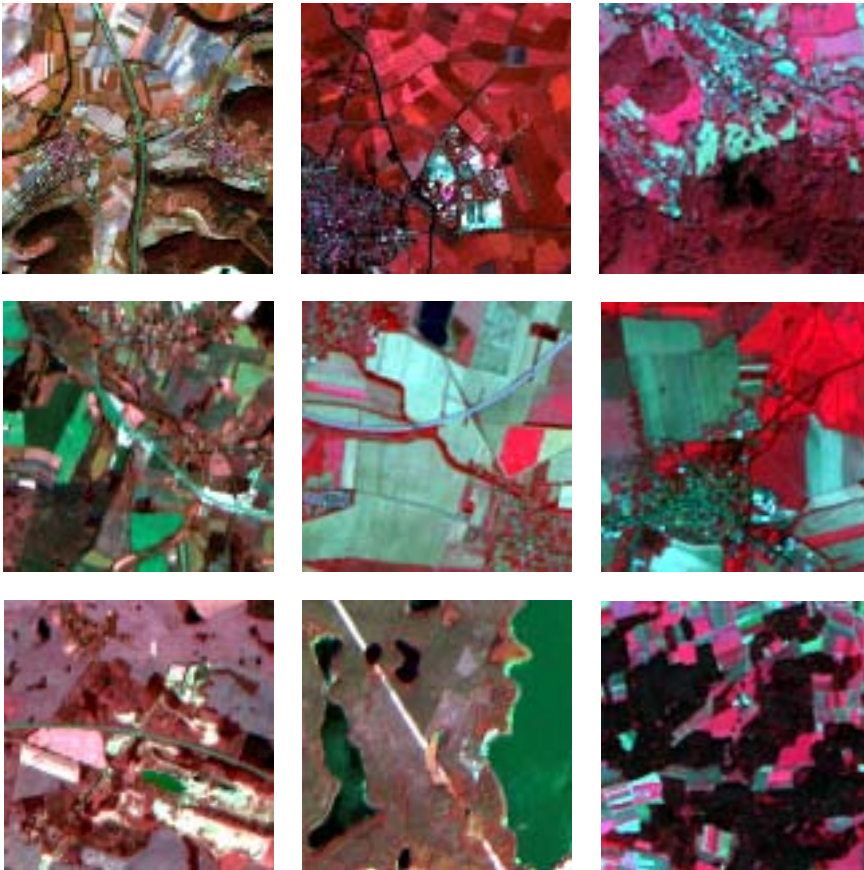



Figure 6-11 Examples of GCP chip images

6.2 Methodology of METRIA

The SIP/Ortho software from Spacemetric is used for geometric modeling and correction of satellite imagery. The software is modular, allowing the different sub-models to easily be replaced and modified to adapt to the needs of new sensor instruments and satellites.

The capabilities of SIP/Ortho are enabled by an integrated database. This provides comprehensive metadata storage and a full range of tools for the creation, use and management of Ground Control Points and image chip libraries. It also supports the several thousand geodetic coordinate systems and map projections defined by the EPSG.

The following chapters discuss aspects of this software related to georeferencing. More details can be found at <http://www.spacemetric.com>.

		<p style="text-align: center;"><i>GMES Fast Track Land Service 2006-2008 Orthorectification of SPOT and IRS-P6 products</i></p> <p>Doc. No.: <i>Image2006</i></p> <p>Issue: <i>1.0</i></p> <p>Date: <i>12th May 2009</i></p> <p>Page: <i>37</i></p>
---	---	--

6.2.1 Line-of-sight model

Optical sensor model

The line-of-sight model (LOS) describes in an analytical way how a pixel in a satellite image is projected onto the ground using a number of distinct sub-models that can be independently modified or replaced. It defines the relations between the sub-models and the flow of transformations involved (Figure 6-12).

Sensor model

The sensor model takes a pixel in the satellite image and computes its look vector \mathbf{u}_s in the sensor coordinate system. It also computes the time for the instance of this look. The sensor model is initialized with parameters for the sensor design. It can be a generic model for a push-broom scanner, which will have parameters such as focal length, detector positions in the focal plane and scan-line time interval. Alternatively, it can be a highly specialized model for a more complicated sensor. The sensor model is the sub-model that is most often modified when implementing a new satellite system.

Body model

The body model is used to rotate the look vector from the sensor coordinate system to the satellite body coordinate system. It is used to model either the intended off-nadir sensor mounts or the small misalignments in the nominal mount.

Attitude model

The attitude model is used to rotate the look vector from the body coordinate system to the flight coordinate system. The rotations between these systems are due to deviations in satellite attitude. This is a time-dependent variation, usually measured by devices such as earth horizon detectors, gyroscopes or star trackers. The attitude model is initiated by a set of time-coded attitude and/or attitude rate measurements. The time of the look is used to calculate the transformation to be used.

Flight model

The flight model is used to rotate the look vector from the flight coordinate system to the Earth Centered Inertial (ECI) coordinate system. It is also used to calculate the position of the satellite. It employs orbital mechanics and is initiated by sets of parameters such as one or several ephemeris, several time-tagged position vectors or two-line elements. The time of the look is used to calculate the transformation and position to be used.

Astronomical model

The astronomical model is used to transform the position and look vectors from the ECI system to the Earth Centered Rotating (ECR) coordinate system. It is primarily a rotation of the x-axis from the vernal equinox to the Greenwich meridian. The transformation is time-dependent and the time of the look is used to calculate the transformation to be used.

Intersection model

The intersection model calculates the intersection point between the look vector and an ellipsoidal Earth centered in the ECR system. The ellipsoidal height is also input to get a unique position. An atmospheric model is applied to correct for the deviation caused by atmospheric refraction.

Geodesy model

The geodesy model transforms the earth intersection point, expressed in ECR coordinates, to a geographic coordinate (longitude, latitude, orthometric height). It uses a geoid model to account for the irregularities in the earth zero potential surface. The result is a coordinate in the WGS84 system.

Map projection

The map projection transforms the geographic coordinate to a cartographic coordinate (x, y, h) , by the use of a map projection that is suitable in the area of the image. There are thousands of different map projections in use for cartographic purposes in different areas all over the globe, all stored and accessed from a database. New user-defined projections can easily be added to the database.

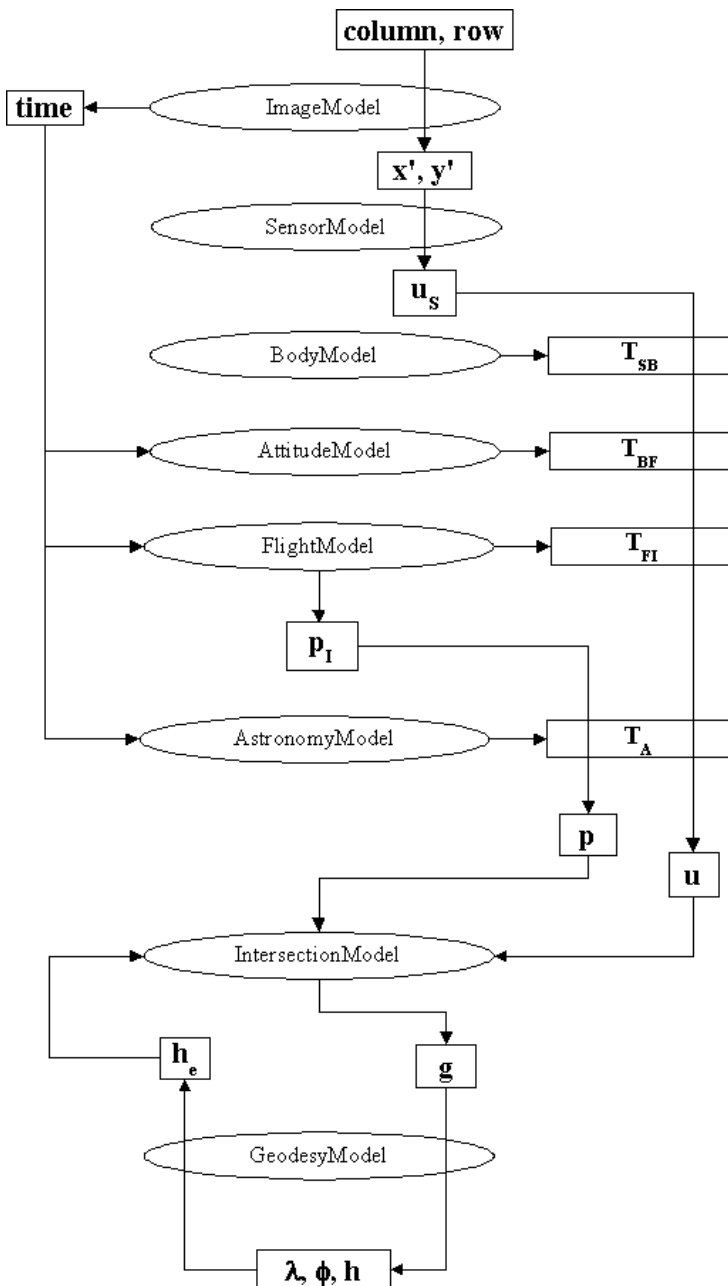





Figure 6-12 The generic observation model used in SIP/Ortho

  		<p style="text-align: center;"><i>GMES Fast Track Land Service 2006-2008 Orthorectification of SPOT and IRS-P6 products</i></p> <p>Doc. No.: <i>Image2006</i></p> <p>Issue: <i>1.0</i></p> <p>Date: <i>12th May 2009</i></p> <p>Page: <i>39</i></p>
---	---	--

Replacement sensor models

In some cases, data for the generation of a full analytical LOS model is not provided in the metadata for the raw satellite image. In those cases, a replacement sensor model (RSM) can be used. Two RSMs are used by Spacemetric:

- Rational functional model (RFM). This is a rational polynomial of 3rd degree. As an example, coefficients for such models are supplied in the metadata for Ikonos and Quickbird.
- 3rd degree polynomial. This height-dependent polynomial can also be used with sufficient accuracy for most satellite sensors.

The parameters to be adjusted in the RSM are selectable and can be weighted, just as the parameters in the analytical models.

6.2.2 Ortho-rectification



When the line-of-sight geometric model is established for an image, it can be used in image orthorectification. The steps involved are:

- Import the image from a standard image format and associate the geometric model with the image.
- Set the output frame parameters. This includes the choice of coordinate system (map projection), bounding rectangle and pixel size for the rectified image. The system can automatically calculate and set the minimum frame that completely contains the rectified image.
- If the image is to be orthorectified then associate a DEM with the image. Otherwise select a reference elevation as the reference surface.
- Compute locations of output pixels in the input image. This inverse line-of-sight transform is not performed for every pixel, as computationally this would be too costly. Instead, it is performed through the use of a regular grid over the image. The density of the grid is adjusted to be small enough that a bilinear interpolation of positions within a grid cell is sufficiently accurate.
- Resample the input image by interpolating the non-integer positions of the output pixels. The interpolation method is selectable. Standard methods, such as cubic convolution, bilinear and nearest neighbour are directly selectable, but any other interpolation/filtering kernel can easily be added to the system in the form of coefficients tables.
- Save the rectified image to disk in the selected image format.

6.2.3 Model parameter adjustment

The parameters of the line-of-sight model can be adjusted to fit a set of ground control points (GCPs). A GCP consists of a 3-dimensional ground coordinate (x, y, h) and its estimated accuracy (sx, sy, sh). An image point (IP) consists of a position in the satellite image (column, row) and its estimated accuracy (scolumn, srow). Marking the position of a GCP in the satellite image consequently gives a constraint on the model parameters. A number of such measurements give rise to a system of constraint equations that can be solved by least-squares adjustment.

An optimal least-squares solution should employ the “generalized least squares” approach. This makes full use of all a priori information, including start values for the parameters and their estimated accuracies.

 <p>METRIA INGÅR I LANTMÄTERIET</p>		<p style="text-align: center;"><i>GMES Fast Track Land Service 2006-2008 Orthorectification of SPOT and IRS-P6 products</i></p> <p>Doc. No.: <i>Image2006</i> Issue: <i>1.0</i> Date: <i>12th May 2009</i> Page: <i>40</i></p>
--	---	---

Details on how the generalized least-squares method is applied to the satellite line-of-sight problem are found in [RD-18] and [RD-19].

Tie-points (TPs) are image measurements that connect locations in different images. In the “generalized least squares” approach, they are treated as Ips with small (zero) variance measured for GCPs with high (infinite) variance. In this way TPs can conveniently be accommodated in the same generalized least-squares solution.

The positioning of GCPs in an image (IP measurement) can be achieved using different tools:

- Manual pointing in an image viewer. Here it must be simple to colour balance the image so that the GCP feature is easy to identify. It is also important that the image can be properly zoomed so that the sub-pixel position of the feature can be measured.
- Automated pointing using image chips. The chip is a small section from another image, extracted around the GCP. The position of the chip in the raw image is found by normalised cross-correlation of image pixel grey levels. It is necessary to correctly re-sample in order to achieve a common geometric space for the chip and raw image. It must also be possible to estimate the sub-pixel location of the best fit. In the case of ground control, the chip is extracted from a previously orthorectified image, while in the case of tie-points, the chip is extracted from the raw image to which it should be tied. It must be possible to handle both these types of chips.

6.2.4 Geometric accuracy performance

Spacemetric software has achieved unsurpassed geometric accuracy in operational environments for many years. The key factors are:

- Precision: Analytical LOS models that are rigorous and well calibrated allow precise modelling of the sensor geometry.
- Robustness: The use of analytical models with carefully weighted parameters makes it possible to achieve high accuracy even when there is limited access to ground control.





The models allow ½ pixel accuracy or better to be achieved if the ground control is of sufficient quality. This has been verified during many years of operational use by Metria in Kiruna, Sweden. Metria has been using Spacemetric systems as a contractor for the supply of imagery for the CwRS for many years.

The system performance is also documented in numerous scientific papers. A selection is provided in references [RD-18] – [RD-28].

6.2.5 Digital Elevation Model (METRIA)

Metria uses the following DEMs:

- Sweden: DEM with 50 m grid distance. The accuracy in z is +/- 2.5 m.
- Norway: DEM with 50 m grid distance. The accuracy in z is +/- 2.5 m.
- Svalbard: DEM with 30 m grid, accuracy in z is +/- 10 m for half of the island, not estimated for the other half.
- Finland: DEM with 25 m grid distance, accuracy in z is +/- 2 m
- Iceland: DEM with 25 m grid distance, accuracy in z is estimated to +/- 10m

  		<p style="text-align: center;"><i>GMES Fast Track Land Service 2006-2008 Orthorectification of SPOT and IRS-P6 products</i></p> <p>Doc. No.: <i>Image2006</i></p> <p>Issue: <i>1.0</i></p> <p>Date: <i>12th May 2009</i></p> <p>Page: <i>41</i></p>
---	---	--

7. Statistics and Results

The following chapters describe the orthorectification and GCP image chip database products and the achieved accuracies of the orthorectification. A detailed description of the orthorectified products as well as the quality assurance record both for the country and each individual scene can be found by following the links listed in Table 7-1.

7.1 Orthorectification Product

Table 7-1 ² lists the documents containing a detailed compilation of the National map projection parameters (CRS), the geometric accuracies of the orthorectified products and the quality record (quality of original images, reference images, DEM, processing) for the whole country as well as for each processed image of the country. The access to these documents is regulated by ESA. The description of the QR (Quality Record) is given in Appendix 4: Quality Record - Description

Albania	Austria	Belgium	Bosnia Herzegovina	Bulgaria	Cypres	Denmark
Ireland	Estonia	Czech Rep.	Finland + Gapfillers	France	Germany	Greece
Croatia	Hungary	Iceland + Gapfillers	Italy	Latvia	Lithuania	Slovakia
Liechtenstein	Luxembourg	Macedonia	Malta	Montenegro	Netherlands	Norway + Gapfillers
Poland	Portugal	Romania	Slovenia	Spain	Serbia	Sweden + Gapfillers
Switzerland	Turkey	United Kingdom				

Table 7-1 Documents containing detailed information for each country and each processed scene

In Table 7-2 the geometric accuracy of the orthorectified data sets subdivided into countries is summarized. As already stated the geometric accuracy is measured with respect to the reference images (Image2000 panchromatic layer or ETM+ USGS Land Cover data) and should be –as required in the SoW- less than 20m RMSE in each direction. About 3800 scenes have been processed and an overall geometric accuracy of less than 10m RMSE in each direction with respect to the IMAGE2000 and USGS Land Cover reference datasets has been achieved, which corresponds to half a pixel size. In case of DLR the accuracy assessment is based on ~450 automatically extracted ICPs per 1000 km².



Legend of Table 7-2 (detailed description)

Coverage

The first coverage (1) contains images of acquisition window one (narrow and extended window; mainly summer) as basis for the production of value-added layers and the second coverage (2) provides a multi-temporal dataset to improve the discrimination of vegetation cover.

Scenes

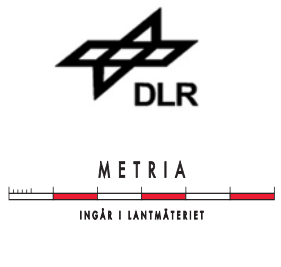
² For the countries Norway, Finland, Sweden and Iceland two files for each country exist due to the late delivery of the gap filling scenes.

		<p style="text-align: center;">GMES Fast Track Land Service 2006-2008 Orthorectification of SPOT and IRS-P6 products</p> <p>Doc. No.: <i>Image2006</i></p> <p>Issue: <i>1.0</i></p> <p>Date: <i>12th May 2009</i></p> <p>Page: <i>42</i></p>
---	---	---

Number of processed scenes cut into SPOT and IRS-P6 imagery.

RMSE (Root Mean Square Error)

The following formulas are used for the determination of the geometric accuracy of the orthoimages (see also Appendix 2: Comments on Accuracy Assessment).

$$RMSE_x = \sqrt{\frac{1}{N} \sum_{i=1}^N (x_i^{ref} - x_i^{ortho})^2} \leq 20m \quad \text{and} \quad RMSE_y = \sqrt{\frac{1}{N} \sum_{i=1}^N (y_i^{ref} - y_i^{ortho})^2} \leq 20m$$

$$RMSE_{xy} = \sqrt{RMSE_x^2 + RMSE_y^2}$$

with N the number of ICPs (Independent Control Points), x_i^{ref}, y_i^{ref} the coordinates of points (ICP) in the reference images and x_i^{ortho}, y_i^{ortho} the corresponding points in the orthorectified images. For the determination of the overall geometric accuracy of a country the root mean square errors of the individual scenes are add up, weighted by the number of found ICPs in a scene.

ICPs / scene

This column describes the mean number of ICPs per scene of a country, calculated by the weighted sum (number of ICPs) of the individual images. The ICPs are used to calculate the remaining residuals (geometric accuracy given by RMSE values) of the orthorectified image

Note: For the northern countries SE, FI, NO and IS there are an additional entry in the Table 7-2 called <CountryCode>-Gapfiller, because there exists an independent Quality Assurance Record (see also Table 7-1) for the gap filling scenes, which has been delivered after finalization of the report in hands. The amount of scenes given in the Gap-Fillers row is not part of the synoptic value.



Image2006

GMES Fast Track Land Service 2006-2008
Orthorectification of SPOT and IRS-P6 products

Doc. No.: Image2006

Issue: 1.0

Date: 12th May 2009

Page: 43

Country	Coverage	SPOT 4 HVIR & SPOT 5 HRG					IRS-P6 LISS III					Synopsis			
		Scenes	RMSE _x [m]	RMSE _y [m]	RMSE _{xy} [m]	ICPs /scene	Scenes	RMSE _x [m]	RMSE _y [m]	RMSE _{xy} [m]	ICPs /scene	RMSE _x [m]	RMSE _y [m]	RMSE _{xy} [m]	ICPs /scenes
Albania	1	9	10,13	8,03	12,93	530	5	7,41	5,72	9,36	5565	7,8	6,06	9,88	2328
	2	3	7,69	7,96	11,06	592	4	8,6	6,19	10,59	2713	8,47	6,44	10,64	1804
Austria	1	20	12,16	9,98	15,73	3585	12	10,35	9,1	13,78	22234	10,74	9,29	14,2	10578
	2	15	11,29	9,45	14,72	8085	15	10,53	8,84	13,75	14051	10,8	9,07	14,1	11068
Belgium	1	9	10,88	8,64	13,9	1475	5	10,25	10,37	14,58	5933	10,44	9,84	14,35	3067
	2	9	11,62	10,29	15,52	1936	3	9,92	10,64	14,54	8614	10,6	10,5	14,92	3605
Bosnia Herzegovina	1	8	4,31	5,58	7,04	44	9	9,03	7,64	11,83	69	7,31	6,89	10,05	57
	2	11	6,33	6,55	9,11	736	6	5,92	6,3	8,65	2890	6,05	6,38	8,79	1496
Bulgaria	1	35	11,8	8,83	14,74	2955	12	11,76	8,33	14,41	10647	11,78	8,55	14,56	4919
	2	19	12,23	10,91	16,39	499	12	12,49	10,65	16,41	2150	12,42	10,72	16,41	1138
Cyprus	1	1	8,17	3,76	8,99	36	2	8,14	5,52	9,83	90	8,14	5,22	9,67	72
	2	0	0	0	0	0	2	6,86	5,84	9,01	1633	6,86	5,84	9,01	1633
Denmark	1	32	10,96	8,55	13,9	351	4	10,63	8,96	13,9	614	10,9	8,62	13,9	380
	2	17	11,05	8,07	13,69	400	8	9,94	7,4	12,39	1830	10,29	7,61	12,8	858
Iceland	1	76	11,45	17,08	20,57	14,4						11,45	17,08	20,57	14
	2														
IS-Gapfillers	1	22	11,06	11,76	16,15	12,4						11,06	11,76	16,15	12
	2														



Image2006

GMES Fast Track Land Service 2006-2008
Orthorectification of SPOT and IRS-P6 products

Doc. No.: Image2006

Issue: 1.0

Date: 12th May 2009

Page: 44

Country	Coverage	SPOT 4 HVIR & SPOT 5 HRG					IRS-P6 LISS III					Synopsis			
		Scenes	RMSE _x [m]	RMSE _y [m]	RMSE _{xy} [m]	ICPs /scene	Scenes	RMSE _x [m]	RMSE _y [m]	RMSE _{xy} [m]	ICPs /scene	RMSE _x [m]	RMSE _y [m]	RMSE _{xy} [m]	ICPs /scenes
Ireland	1	29	12,81	11,25	17,05	1500	10	11,34	11,16	15,91	2747	12,24	11,21	16,6	1820
	2	33	12,8	12,16	17,66	835	6	12,64	12,75	17,95	2124	12,83	12,43	17,87	1037
Estonia	1	15	10,61	7,44	12,96	1840	7	9,67	6,47	11,63	3079	10,2	7,01	12,38	2234
	2	1	10,72	6,58	12,57	418	8	10,6	7,35	12,9	1139	10,6	7,32	12,88	1059
Czech Republic	1	18	11,33	8,68	14,28	4943	8	10,65	8,82	13,83	9395	11,02	8,75	14,07	6313
	2	10	11,42	9,59	14,91	1865	13	10,17	8,76	13,42	9328	10,34	8,87	13,62	6083
Finland	1	40	8,9	8,05	12,0	16	47	7,69	7,47	10,72	17	8,24	7,72	11,29	16
	2	40	6,01	6,41	8,79	10	36	6,73	6,86	9,61	16	6,46	6,69	9,3	13
<i>FI-Gapfillers</i>	1	4	8,59	9,94	13,14							8,59	9,94	13,14	8
	2	19	9,75	7,99	12,61		2	7,92	11,51	13,97	17	9,59	8,39	12,74	14
France	1	145	12,55	10,51	16,37	847	47	10,86	9,55	14,46	9256	11,37	9,84	15,03	1773
	2	33	10,91	9,07	14,19	1081	62	10,75	9,84	14,57	1241	10,8	9,59	14,45	1186
Germany	1	100	10,48	8,6	13,56	3776	44	9,77	9,29	13,48	9710	10,11	8,97	13,51	5589
	2	22	11,3	9,96	15,07	1858	41	10,39	9,72	14,23	4389	10,56	9,77	14,38	3505
Greece	1	75	12,09	9,1	15,13	1437	21	11,61	7,32	13,72	13804	11,74	7,8	14,09	4142
	2	25	11,49	8,66	14,39	963	34	11,72	7,17	13,74	10087	11,71	7,27	13,78	6221
Croatia	1	12	6,45	6,46	9,12	125	10	11,27	8,91	14,37	1405	10,8	8,67	13,85	707
	2	10	7,29	5,93	9,4	848	10	6,34	6,19	8,86	5324	6,47	6,15	8,93	3086
Hungary	1	36	11,73	11,42	16,37	271	5	10,91	6,65	12,77	1496	11,37	9,35	14,73	421
	2	9	13,3	10,7	17,07	96	10	11,05	10,02	14,91	229	11,67	10,2	15,5	166



Image2006

GMES Fast Track Land Service 2006-2008
Orthorectification of SPOT and IRS-P6 products

Doc. No.: Image2006

Issue: 1.0

Date: 12th May 2009

Page: 45

Country	Coverage	SPOT 4 HVIR & SPOT 5 HRG					IRS-P6 LISS III					Synopsis			
		Scenes	RMSE _x [m]	RMSE _y [m]	RMSE _{xy} [m]	ICPs /scene	Scenes	RMSE _x [m]	RMSE _y [m]	RMSE _{xy} [m]	ICPs /scene	RMSE _x [m]	RMSE _y [m]	RMSE _{xy} [m]	ICPs /scenes
Italy	1	57	10,16	7,83	12,83	847	37	10,14	8,11	12,99	9561	10,14	8,08	12,97	4277
	2	92	9,37	7,77	12,17	1335	41	9,49	7,49	12,09	4227	9,44	7,61	12,12	2226
Latvia	1	20	11,44	8,48	14,24	2180	6	9,77	6,85	11,93	3854	10,86	7,92	13,44	2566
	2	4	10,05	8,94	13,45	1029	8	10,64	6,61	12,53	1789	10,51	7,13	12,7	1536
Lithuania	1	26	10,75	6,75	12,70	1240	4	9,69	6,1	11,45	3661	10,42	6,55	12,31	1563
	2	14	11,77	8,82	14,7	700	7	11,59	7,23	13,66	528	11,72	8,38	14,41	643
Slovakia	1	17	13,04	8,63	15,64	2544	5	10,75	7,34	13,02	4025	12,32	8,22	14,81	2880
	2	5	11,17	7,03	13,19	129	6	10,97	7,92	13,53	6823	10,99	7,8	13,48	4311
Liechtenstein	1						1	10,98	7,14	13,1	19980	10,98	7,14	13,1	19980
	2	1	17,26	7,63	18,88	6030						17,26	7,63	18,88	6030
Luxembourg	1	2	10,6	9,42	14,18	2411	1	10,39	10,95	15,09	8157	10,47	10,38	14,74	4326
	2	3	12,29	11,69	16,96	2921						12,29	11,69	16,96	2921
Macedonia	1	3	10,97	13,82	17,64	775	6	11,57	7,02	13,54	10150	11,55	7,27	13,65	7025
	2	4	9,96	9,17	13,54	2676	3	13,34	8,72	15,94	3896	11,72	8,94	14,74	3199
Malta	1						1	5,04	9,05	10,36	461	5,04	9,05	10,36	461
	2	1	10,39	12,34	16,13	20						10,39	12,34	16,13	20
Montenegro	1	3	9,8	8,23	12,8	301	3	6,43	6,05	8,83	4812	6,63	6,18	9,07	2556
	2	4	7,99	10,74	13,38	87	2	6,85	8,43	10,87	715	7,08	8,88	11,36	297
Netherlands	1	24	10,78	8,84	13,94	1041	5	9,68	8,31	12,76	5422	10,21	8,57	13,33	1797



Image2006

GMES Fast Track Land Service 2006-2008
Orthorectification of SPOT and IRS-P6 products

Doc. No.: *Image2006*

Issue: *1.0*

Date: *12th May 2009*

Page: *46*

Country	Coverage	SPOT 4 HVIR & SPOT 5 HRG					IRS-P6 LISS III					Synopsis			
		Scenes	RMSE _x [m]	RMSE _y [m]	RMSE _{xy} [m]	ICPs /scene	Scenes	RMSE _x [m]	RMSE _y [m]	RMSE _{xy} [m]	ICPs /scene	RMSE _x [m]	RMSE _y [m]	RMSE _{xy} [m]	ICPs /scenes
	2	23	11,38	10,05	15,18	1024	2	10,24	9,54	14	1445	11,25	9,99	15,05	1058
Norway	1	71	6,93	7,7	10,36	15	57	6,35	6,81	9,31	19	6,67	7,31	9,9	17
	2	161	6,28	6,11	8,77	11	6					6,28	6,11	8,77	11
<i>NO-Gapfiller</i>	1														
	2	37	7,44	7,1	10,28	12,2	6	3,99	4,06	5,69	13	7,06	6,76	9,77	12
Poland	1	62	11,78	8,77	14,69	1992	29	11,08	7,98	13,65	2436	11,53	8,48	14,31	2134
	2	19	11,4	8,04	13,96	802	31	10,39	7,29	12,69	2546	10,55	7,41	12,9	1883
Portugal	1	15	10,59	8,81	13,38	1173	12	10,19	8,47	13,25	10873	10,24	8,43	13,27	5484
	2	24	12,79	10,17	16,34	701	10	10,32	8,51	13,38	14289	10,58	8,69	13,69	4697
Romania	1	44	12,58	7,84	14,82	1133	24	11,89	8,29	14,5	1272	12,32	8,01	14,69	1182
	2	42	11,22	8,11	13,85	510	21	12,81	9,97	16,23	531	11,77	8,75	14,66	517
Slovenia	1	9	9,7	8,02	12,59	5666	2	11,86	9,67	15,3	23374	10,74	8,81	13,89	8886
	2	7	13,41	7,76	15,49	4283	3	12,02	11,43	16,59	2873	13,1	8,58	15,66	3860
Spain	1	44	10,22	8,35	13,2	2657	59	10	8,55	13,15	33573	10,01	8,54	13,16	20366
	2	41	9,79	7,77	12,5	2582	65	10,23	8,51	13,3	22409	10,2	8,46	13,25	14740
Serbia	1	32	13,68	8,31	16,01	276	8	7,9	6,47	10,21	4018	9,18	6,87	11,47	1006
	2	11	8,18	7,61	11,18	1435	12	9,24	7,04	11,61	395	8,43	7,48	11,27	892
Sweden	1	115	9,36	6,58	11,44	15	42	7,93	6,21	10,07	15	9	6,48	11,09	15
	2	42	9,66	7,14	12,01	16	37	8,32	7,61	11,27	16	9,03	7,37	11,66	16
<i>SE-Gapfiller</i>	1														
	2	4	6,65	5,02	8,33	11,5	1	4,2	3,24	5,3	15	6,24	4,72	7,82	12



Image2006

GMES Fast Track Land Service 2006-2008
Orthorectification of SPOT and IRS-P6 products

Doc. No.: *Image2006*
Issue: *1.0*
Date: *12th May 2009*
Page: *47*

Country	Coverage	SPOT 4 HVIR & SPOT 5 HRG					IRS-P6 LISS III					Synopsis			
		Scenes	RMSE _x [m]	RMSE _y [m]	RMSE _{xy} [m]	ICPs /scene	Scenes	RMSE _x [m]	RMSE _y [m]	RMSE _{xy} [m]	ICPs /scene	RMSE _x [m]	RMSE _y [m]	RMSE _{xy} [m]	ICPs /scenes
Switzerland	1	17	10,53	5,66	11,96	153	5	6,26	5,96	8,64	91	9,58	5,73	11,16	133
	2	8	12,83	8,97	15,66	267	7	6,35	6,96	9,42	516	8,76	7,7	11,67	383
Turkey	1	81	8,45	6,59	10,71	697	86	6,49	5,27	8,36	3779	6,78	5,46	8,71	2284
	2	71	8,48	7,71	11,46	1115	69	6,23	5,72	8,46	2912	6,87	6,29	9,32	1994
United Kingdom	1	108	11,03	9,21	14,37	1672	23	9,21	7,02	11,58	5031	10,32	8,35	13,27	2275
	2	155	10,99	10,02	14,87	833	15	7,88	6,51	10,23	435	10,91	9,93	14,75	814
Synopsis		2399	10,32	8,56	13,47	1273	1279	9,49	7,91	12,41	5271	10,13	8,32	13,02	2923

Table 7-2 Geometric accuracy (w.r.t. reference images) of orthorectified country datasets

7.2 GCP Chip Database Product

The GCP image chip database is structured on a country basis (this is different to the description of the ICD with all GCP chips in one directory; handling becomes difficult of such a huge amount of files in one single folder).

The requirement is to extract more than 15 GCPs per 3600 km² (~4.2 GCPs per 1000 km²).

The GCP chips are derived from the orthorectified images in European Projection (Lambert Azimuthal Equal Area ETRF89) of size 101x101 pixels from the first coverage.

The GCPs are 3D coordinates (easting: X, northing: Y, ellipsoid height: Z) of the center of the center pixel of the image chip ("pixel is point" definition). The ellipsoid heights are extracted and interpolated from the DEM at the planar coordinates of the GCP. The content of the GCP directory are PNG files with the naming convention

<CoordinateX>_<CoordinateY>_<CoordinateZ>.png

where the coordinates <CoordinateX> and <CoordinateY> and <CoordinateZ> are integer values with unit meter.

For the GCP chips derived from Spot 4/5 and IRS-P6-LISS III data the channels 1,2 and 3 are used with (1=Green, 2=Red, 3=NIR).

Table 7-3 shows the GCP statistics of the image chip database on a country basis.

Country	Area [km ²]	Number of GCPs	GCPs / 1000 km ²
Albania	28748	489	17,0
Austria	83855	1437	17,1
Belgium	30520	506	16,6
Bosnia Herzegovina	51130	1006	19,7
Bulgaria	110994	1812	16,3
Croatia	56538	972	17,2
Cyprus	9251	79	8,5
Czech Republic	78864	1146	14,5
Denmark	43075	726	16,9
Estonia	45200	725	16,0
Finland	338145	897	2,7
France	543965	6371	11,7
Germany	357028	5193	14,5
Greece	131957	2601	19,7
Hungary	93030	1080	11,6
Iceland	102820	498	4,8
Ireland	70282	1031	14,7



METRIA



Image2006

GMES Fast Track Land Service 2006-2008
Orthorectification of SPOT and IRS-P6 products

Doc. No.: *Image2006*



Issue: *1.0*

Date: *12th May 2009*

Page: *49*

Country	Area [km ²]	Number of GCPs	GCPs / 1000 km ²
Italy	301245	3855	12,8
Latvia	63700	760	11,9
Liechtenstein	160	86	537,5
Lithuania	65200	888	13,6
Luxemburg	2586	123	47,6
Macedonia	25713	624	24,3
Malta	316	20	63,3
Montenegro	13812	298	21,6
Netherlands	41526	864	20,8
Norway	323878	1447	4,5
Poland	312683	3450	11,0
Portugal	92019	959	10,4
Romania	237500	2727	11,5
Serbia	88361	1421	16,1
Slovakia	49035	776	15,8
Slovenia	20251	367	18,1
Spain	504782	5355	10,6
Sweden	449964	1655	3,7
Switzerland	41293	617	14,9
Turkey	789452	5200	6,6
United Kingdom	244082	2992	12,3
Total	5842960	61053	

Table 7-3 GCP image chip database on a country basis

		<p style="text-align: center;"><i>GMES Fast Track Land Service 2006-2008 Orthorectification of SPOT and IRS-P6 products</i></p> <p>Doc. No.: <i>Image2006</i> Issue: <i>1.0</i> Date: <i>12th May 2009</i> Page: <i>50</i></p>
--	---	--

8. Appendix 1: Country Reference Systems CRS

In order to establish a database for the correct map projection parameters of the countries (including geodetic datum transformation parameters) the following procedure has been applied

- Basis for CRS acquisition were the following documents and tables
 - Initial version of CRS tables received from ESA at the beginning of the Image2006 project
 - Table of CRS from IMAGE2000 project [ID-09]
 - Document MAP PROJECTIONS FOR EUROPE [ID-04]
- In case the map projection parameters for a country are not clear the official contact person of the country has been asked via e-mail to provide these parameters
- Additionally the map projection parameters have been cross checked with other information (articles and columns in "Photogrammetric Engineering & Remote Sensing – Grids & Datums" and <http://crs.bkg.bund.de/crs-eu/index.html>)
- Response of the National experts are taken into account with highest priority

The geodetic datum parameters are specified by the following transformation formula, where $(x^{WGS84}, y^{WGS84}, z^{WGS84})$ are the ECEF Cartesian coordinates in WGS84 and $(x^{CRS}, y^{CRS}, z^{CRS})$ are the ECEF Cartesian coordinates in the National CRS. The datum transformation formula, as used in the table, is given by

$$\begin{bmatrix} x^{WGS84} \\ y^{WGS84} \\ z^{WGS84} \end{bmatrix} = \begin{bmatrix} dx \\ dy \\ dz \end{bmatrix} + (1+s) \cdot \begin{bmatrix} 1 & rz & -ry \\ -rz & 1 & rx \\ ry & -rx & 1 \end{bmatrix} \cdot \begin{bmatrix} x^{CRS} \\ y^{CRS} \\ z^{CRS} \end{bmatrix}$$

It is noted that there are different definitions of the geodetic datum transformation formula (e.g. Bursa-Wolff, Pointing Vector and so on using an alternative sign of the rotation angles or exchange the rotation axes). Therefore special caution is advised.

9. Appendix 2: Comments on Accuracy Assessment

The geometric accuracy requirement for Image2006 products is specified as $\sigma_x = \sigma_y = 20\text{m}$ for the National and European product and specifies therefore a linear error in each direction. In case of $\sigma_x = \sigma_y$ this corresponds to the Circular Standard Error (CSE), which means that about 39% (CE39) of the measures are within a circle of 20m. It is noted that normally a Mean Square Positional Error MSPE is used to specify positional errors, which is given by the root of the quadratic sum of the linear errors. This error definition describes, that about 63% of measures are within a circle of the specified radius (MSPE = CE63) and is therefore comparably with the "one sigma" specifications in the one dimensional case [Figure 9-1]. Often the pointing knowledge is specified using the CE90 error definition.

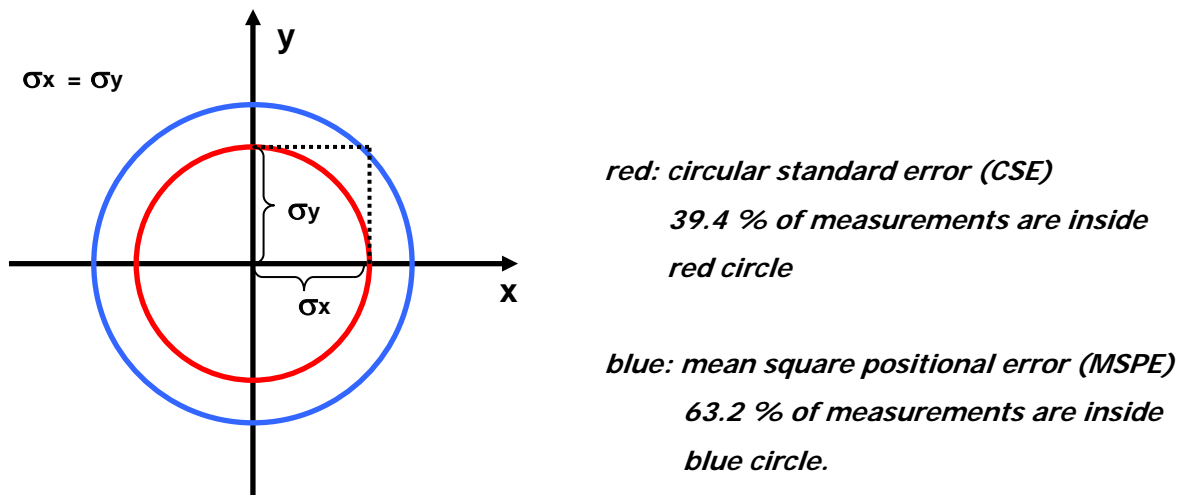

Figure 9-1 Different Accuracy Specifications

The requirement for the geometric accuracy of the produced orthoimages are specified independently for the two directions (x =east, y =north) with respect to the reference orthoimages by

$$RMSE_x < 20\text{m}$$

$$RMSE_y < 20\text{m}$$

It is noted, that the maximum resulting 2D-accuracy using MSPE can be therefore

$$RMSE_{xy} = \sqrt{RMSE_x^2 + RMSE_y^2} = 28.2\text{m}$$

The $RMSE$ values given in the final report are determined from the remaining residuals between the produced orthoimages and the reference orthoimages, mainly by ICPs automatically derived from image matching techniques. The number of ICPs for the $RMSE$ calculations (in case of automatic determination using image matching methods) depends on the image content and counts about 100-1000 points for each scene. It is also noted, that the absolute geometric accuracy of the reference data set Image2000, which is used for GCP and ICP extraction, is given by $RMSE_{xy} < 25\text{m}$.



METRIA



Image2006

GMES Fast Track Land Service 2006-2008
Orthorectification of SPOT and IRS-P6 products

Doc. No.: Image2006

Issue: 1.0





Date: 12th May 2009

Page: 52

10. Appendix 3: Country Codes

Country Code	Country Name
AL	Albania
AT	Austria
BE	Belgium
BA	Bosnia and Herzegovina
BG	Bulgaria
CY	Cyprus
DK	Denmark
IE	Ireland
EE	Estonia
CZ	Czech Republic
FI	Finland
FR	France
DE	Germany
GR	Greece
HR	Croatia
HU	Hungary
IS	Iceland
IT	Italy
LV	Latvia
LT	Lithuania
SK	Slovakia
LI	Liechtenstein
LU	Luxembourg
MC	Macedonia
MT	Malta
ME	Montenegro
NI	Northern Ireland (special handling of NI data)
NL	Netherlands
NO	Norway
PL	Poland
PT	Portugal
RO	Romania
SI	Slovenia
ES	Spain
CS	Serbia
SE	Sweden
CH	Switzerland
TR	Turkey
GB	United Kingdom

Table 10-1 Official Country Codes of EU38

  		<p style="text-align: right;">GMES Fast Track Land Service 2006-2008 Orthorectification of SPOT and IRS-P6 products</p> <p>Doc. No.: <i>Image2006</i></p> <p>Issue: <i>1.0</i></p> <p>Date: <i>12th May 2009</i></p> <p>Page: <i>53</i></p>
---	---	--

11. Appendix 4: Quality Record - Description

For each country the QR is composed of

- Change sheet with country mosaic containing country border lines
- Description of CRS (Country Reference System) including test coordinates
- Geometric accuracy for coverage 1 and coverage 2
 - ➔ Overall geometric accuracy of country
 - ➔ Geometric accuracy of each scene of the country
- Manually determined quality assurance record QAR for coverage 1 and coverage 2
 - ➔ Overall quality items of country
 - ➔ Quality items for each scene of the country
- Gaps of country coverage (optional, if gaps)

The meanings of the parameters in the external QR documents for the countries is listed in Table 11-1

RMSE_x	Root Mean Square Error in x direction (east, west)
RMSE_y	Root Mean Square Error in y direction (north, south)
RMSE_{xy}	Root Mean Square Error in xy direction (Mean Square Positional Error MSPE) – see also <i>Appendix 2: Comments on Accuracy Assessment</i>
ICP	Independent Control Points <ul style="list-style-type: none"> ➔ for whole country: the mean number of ICPs per scene (weighted) used for determination of geometric RMSE values ➔ for scene: number of ICPs found in the image and used for determination of the geometric RMSE values
Scene	Orthorectified image(s)
CC	Cloud Coverage (scene and reference) – <i>visually determined</i>
RQ	Radiometric Quality (scene and reference) – <i>visually determined</i> <ul style="list-style-type: none"> ➔ OK: very good radiometric quality ➔ Problematic: more or less good radiometric quality
MQ	Mosaicking Quality of reference images used for this area (Image2000 or USGS data set) – <i>visually determined</i> <ul style="list-style-type: none"> ➔ OK: very good mosaicking quality ➔ Problematic: more or less good mosaicking quality
VI	Visual Interpretation of DEM (blunders, negative heights for Europe, intersection lines, artifacts,...)
Matching	Comments on results of (automatic) image matching between scene and reference in order to derive GCPs for parameter estimation and ICPs for geometric quality control e.g. equal GCP/ICP distribution, areas of larger residuals, to few points found and so on.

Table 11-1 Quality Control – Meanings of parameters

	<h1>Image2006</h1>	<p style="text-align: center;"><i>GMES Fast Track Land Service 2006-2008 Orthorectification of SPOT and IRS-P6 products</i></p> <p>Doc. No.: <i>Image2006</i></p> <p>Issue: <i>1.0</i></p> <p>Date: <i>12th May 2009</i></p> <p>Page: <i>54</i></p>
---	--------------------	--

The values in the "Overall Quality" tables are mean values derived from the "Scene Quality" columns. They only serve as indicator for the overall quality of the country (100% optimal, <100% lower quality) in comparison to the other countries.



METRIA



INGÅR I LANTMÄTERIET

Image2006

GMES Fast Track Land Service 2006-2008
Orthorectification of SPOT and IRS-P6 products

Doc. No.: *Image2006*

Issue: *1.0*

Date: *12th May 2009*

Page: *55*

- END OF DOCUMENT -